

# MATERIAL PART LIST

for M-3830

ITEM NO.	NO.	N A M E	DESCRIPTION	CONTENTS	REVISED	REMARKS
1	1	C. P. U.	92DM → 92DM(820-54)			REV
2	2	"	92DS → 92DS(820-56)			REV
3	12	P. C. B.	155.3 × 73.5 → 155.3 × 73.5 × 1.6t			REV
4	13	"	53.5 × 23.5 → 53.5 × 23.5 × 1.6t			REV
5	14	"	15.7 × 13.0 → 15.7 × 13.0 × 1.6t			REV
6	15	"	70.1 × 36.6 → 70.1 × 36.6 × 1.6t			REV
7	48	TRANSISTOR	C945(3875) 4ea → C945(KTC3875SY) 1ea			DEC
8	49	"	C3121 → KTC3121RTK			REV
9	50	"	A733/BF909/BF910(1504) → A733(KTA1504S)			REV
10	54	CERAMIC CAP	8ea C4~ C10,35 → 9ea C4 ~C10,34,35			INC
11	58	"	473 → 683			REV
12	83	JACK TERMINAL	M 3850 → 16.0 × 5 φ			REV
13	94	M.F.R. 1/4W D	5.2 KΩ → 5.19KΩ			REV
14	99	FUSE CHIP	P.C.B. TYPE → 1A3399-10			REV
15	100	"	P.C.B. TYPE → 1A1119-10			REV
16	101	M.N.W.R. 1W	4.5 / 1W → 4.5 Ω			REV
17	102	" 1W	0.5 / 178W → 0.5 Ω			REV
18	103	" 10W	0.005/ 10W → 0.005 Ω			REV

Next page to continue.....



※ 생산 1과 문안재 기사의 요청에 의하여 수정함.

NO : 3rd Rev.

MODEL : M-3830

DATE : Dec. 21, 1993.

PAGE : 7

CHARGE	CHECKED	APPROVED
		

# MATERIAL PART LIST

for M-3830

ITEM NO.	NO.	N A M E	DESCRIPTION	CONTENTS	REVISED	REMARKS
19	118	KNOB	M 3830 → 45 φ			REV
20	122	JACK TERMINAL MOLD	1ea → 3ea			INC
21	123	JACK TERMINAL MOLD	BLACK 1ea			INS
22	128	KEY RUBBER	M 3270 → A			REV
23	129	"	M 3850 → B			REV
24	130	RUBBER FOOT	M 36B → LARGE			REV
25	131	"	M 3850 → SMALL			REV
26	133	SHIELD PAPER	M 3850 → 250 V / 800 mA			REV
27	140	INTER CONNECTOR A	69.5 × 24.0 × 1.7t → 69.5 × 23.7 × 1.8t			REV
28	141	INTER CONNECTOR B	69.5 × 18.8 × 1.7t → 69.5 × 18.8 × 1.8t			REV
29	147	SCREW	M2.6 × 7.0 (NICKEL) 3ea			DEL
30	148	"	M2.6 × 3.0 2ea			DEL
31	153	RS232C CABLE	6 PIN → 6 PIN (MT/RS232C)			REV
32	159	AIR BAG	1ea			INS
33	160	SPONGE	1ea			INS
34	161	CONTACT	4ea			INS
35	162	TEST LEAD	RED / BLACK 1pair			INS
36	163	BATTERY	9 V (FC-1) 1ea			INS
37	164	CARRYING CASE	M 3830 1ea			INS
38	165	GIFT BOX	M 3830 1ea			INS
39	166	MANUAL	M 3830 1ea			INS
40	167	PROGRAMED FLOOPY	5.25 INCH (2D) 1ea			INS
41	168	"	3.5 INCH (2HD) 1ea			INS
42	169	SOLDER	1.2 φ × 60 % 20g			INS
43	170	PUSH KNOB	RED 1ea			INS

MATERIAL PART LIST

Model : M 3830

Date : Dec. 21, 1993

NO	N A M E	RATINGS & DIMENSION	UNIT	Q'TY	PART NO.	자재코드	REMARKS
1	C. P. U.	92DM(820-54)	ea	1	IC1		S.M.D. TYPE (80 PIN)
2	C. P. U.	92DS(820-56)	ea	1	IC2		S.M.D. TYPE (80 PIN)
3	L. S. I.	MAX134 CMH	ea	1	IC3		S.M.D. TYPE (44 PIN)
4	I. C.	CD4011	ea	1	IC4		S.M.D. TYPE (14 PIN)
5	I. C.	ICM7555	ea	1	IC5		S.M.D. TYPE (8 PIN)
6	I. C.	TL062	ea	2	IC6,7		S.M.D. TYPE (8 PIN)
7	I. C.	CD4027	ea	1	IC8		S.M.D. TYPE (16 PIN)
8	I. C.	CD4066	ea	1	IC11		S.M.D. TYPE (14 PIN)
9	I. C.	PC817	ea	2	IC9,10		D.I.P. TYPE (4 PIN)
10	I. C.	OP07	ea	1	IC13		D.I.P. TYPE (8 PIN)
11	HYBRID I.C.	HD-08	ea	1	IC12		
12	P. C. B.	155.3 × 73.5×1.6t	ea	1			MAIN
13	P. C. B.	53.5 × 23.5×1.6t	ea	1			SUB
14	P. C. B.	15.7 × 13.0×1.6t	ea	1			AC ZERO 용
15	P. C. B.	70.1 × 36.6×1.6t	ea	1			BACK LIGHTING 용
16	CRYSTAL	32.768 KHz	ea	1	XT1		SMALL TYPE
17	CRYSTAL	38.400 KHz	ea	2	XT2,3		
18	CRYSTAL	4.1856 MHz	ea	1	XT4		
19	ARRY RESISTER	6 PIN 100 K	ea	1	RA1		BECKMAN
20	ARRY RESISTER	9 PIN 100 K	ea	1	RA2		BECKMAN
21	C.F.R. 1/4W D	1.8 MΩ	ea	1	R63		CHIP TYPE
22	C.F.R. 1/4W J	100 KΩ	ea	14	R1 ~ R14		CHIP TYPE
23	C.F.R. 1/4W J	330 KΩ	ea	2	R16,17		CHIP TYPE
24	C.F.R. 1/4W J	1.3 KΩ	ea	1	R64		CHIP TYPE
25	C.F.R. 1/4W J	750 Ω	ea	2	R18,19		CHIP OTYPE

MATERIAL PART LIST

Model : M 3830

Date : Dec. 21, 1993

NO	NAME	RATINGS & DIMENSION	UNIT	Q'TY	PART NO.	자재코드	REMARKS
26	C.F.R. 1/4W J	3.3 K $\Omega$	ea	2	R20,21		CHIP TYPE
27	C.F.R. 1/4W J	7.5 K $\Omega$	ea	1	R22		CHIP TYPE
28	C.F.R. 1/4W J	10 K $\Omega$	ea	5	R28,29,30,31,71		CHIP TYPE
29	C.F.R. 1/4W J	5.6 K $\Omega$	ea	1	R32		CHIP TYPE
30	C.F.R. 1/4W J	51 K $\Omega$	ea	1	R33		CHIP TYPE
31	C.F.R. 1/4W J	390 K $\Omega$	ea	1	R34		CHIP TYPE
32	C.F.R. 1/4W J	2.2 M $\Omega$	ea	3	R35,36,37		CHIP TYPE
33	C.F.R. 1/4W J	130 K $\Omega$	ea	1	R39		CHIP TYPE
34	C.F.R. 1/4W J	200 K $\Omega$	ea	2	R40,41		CHIP TYPE
35	C.F.R. 1/4W J	150 $\Omega$	ea	4	R46,47,48,49		CHIP TYPE (BACK LIGHT)
36	C.F.R. 1/4W J	1 M $\Omega$	ea	4	R43,44,45,72		CHIP TYPE
37	C.F.R. 1/4W J	910 K $\Omega$	ea	1	R42		CHIP TYPE
38	C.F.R. 1/4W F	3 K $\Omega$	ea	1	R26		CHIP TYPE
39	C.F.R. 1/4W F	3.6 K $\Omega$	ea	1	R27		CHIP TYPE
40	C.F.R. 1/4W F	7.5 K $\Omega$	ea	1	R25		CHIP TYPE
41	POSISTOR	1.5 K $\Omega$	ea	2	PTC1,2		
42	SW. DIODE	KDS 184	ea	4	D1 ~ D4		B3 (S.M.D. TYPE)
43	SW. DIODE	KDS 193/196	ea	10	D5 ~ D14		F/G3 (S.M.D. TYPE)
44	SW. DIODE	KDS 226	ea	2	D15,16		C3 (S.M.D. TYPE)
45	REC. DIODE	1N4007	ea	9	D17 ~ D24,D26		
46	REF. DIODE	1.2 V (BJ04)	ea	1	D25		
47	TRANSISTOR	MPSA42 (MMBTA42)	ea	2	Q1,2		S.M.D. TYPE (AAX)
48	TRANSISTOR	C945 (KTC3875SY)	ea	1	Q3		S.M.D. TYPE (ALY)
49	TRANSISTOR	KTC3121RTK	ea	1	Q4		S.M.D. TYPE (VA)
50	TRANSISTOR	A733(KTA1504S)	ea	2	Q5,6		S.M.D. TYPE (ASY)

MATERIAL PART LIST

Model : M 3830

Date : Dec. 21, 1993

NO	N A M E	RATINGS & DIMENSION	UNIT	Q'TY	PART NO.	자재코드	REMARKS
51	F. E. T.	K192A	ea	1	Q7		
52	CERAMIC CAP	221	ea	2	C1,2		CHIP TYPE
53	CERAMIC CAP	10 p	ea	1	C3		CHIP TYPE
54	CERAMIC CAP	104	ea	9	C4~C10,34,35		CHIP TYPE
55	CERAMIC CAP	103	ea	2	C11,12		CHIP TYPE
56	CERAMIC CAP	33 p	ea	2	C13,14		CHIP TYPE
57	CERAMIC CAP	22 p	ea	4	C15 ~ C18		CHIP TYPE
58	CERAMIC CAP	683	ea	1	C33		CHIP TYPE
59	CERAMIC CAP	100 p	ea	1	C36		CHIP TYPE
60	CERAMIC CAP	221	ea	1	C37		
61	T. C.	4.7 uF	ea	1	C19		CHIP TYPE
62	T. C.	0.33 uF	ea	1	C28		
63	SURGE CAP	102 / 1KV	ea	1	C20		
64	M.P.F.C.	223 ( 0.022 )	ea	2	C21,22		SMALL BOX TYPE
65	M.P.F.C.	472 ( 0.0047 )	ea	1	C23		SMALL BOX TYPE
66	M.P.F.C.	104	ea	1	C24		SMALL BOX TYPE
67	M.P.F.C.	224	ea	1	C25		SMALL BOX TYPE
68	E. C.	0.33 uF	ea	2	C26,27		
69	E. C.	10 uF	ea	1	C38		
70	E. C.	1.0 uF	ea	1	C29		
71	E. C.	22 uF	ea	1	C30		
72	E. C.	47 uF	ea	2	C31,32		
73	BUZZER	PIEZO BUZZER (20 φ)	ea	1	BZ1		
74	M.G.V.R.	500 Ω	ea	1	VR2		REFERENCE 조정용
75	M.G.V.R.	100 KΩ	ea	1	VR4		DC VOLT 조정용

MATERIAL PART LIST

Model : M 3830

Date : Dec. 21, 1993

NO	N A M E	RATINGS & DIMENSION	UNIT	Q'TY	PART NO.	자재코드	REMARKS
76	M.G.V.R.	200 Ω	ea	1	VR1		AC GAIN 조정용
77	M.D.V.R.	20 KΩ	ea	1	VR3		AC ZERO 조정용
78	M.D.V.R.	500 Ω	ea	1	VR5		CAPACITANCE 조정용 (HI)
79	M.D.V.R.	300 KΩ	ea	1	VR6		CAPACITANCE 조정용 (LO)
80	PUSH SWITCH	2C2P SELF LOCK	ea	1	SW1		DLT-2201
81	T.R. SOCKET	8 PIN ROUND	ea	1			
82	HOUSING	RS-232C MOLEX	ea	1			6 PIN
83	JACK TERMINAL	16.0 × 5 φ	ea	4			
84	M.F.R. 1/2W D	10 MΩ	ea	1	R50		
85	M.F.R. 1/2W D	9.95 MΩ	ea	1	R51		
86	M.F.R. 1/4W D	1.1111 MΩ	ea	1	R52		
87	M.F.R. 1/4W D	101.01 KΩ	ea	1	R53		
88	M.F.R. 1/4W D	10.01 KΩ	ea	1	R54		
89	M.F.R. 1/4W D	1.000 KΩ	ea	1	R55		
90	M.F.R. 1/4W D	1.2 MΩ	ea	1	R56		
91	M.F.R. 1/4W D	301 KΩ	ea	2	R57,58		
92	M.F.R. 1/4W D	1 MΩ	ea	1	R59		
93	M.F.R. 1/4W D	5.62 KΩ	ea	2	R60,61		
94	M.F.R. 1/4W D	5.19 KΩ	ea	1	R62		
95	M.F.R. 1/4W F	75 Ω	ea	1	R65		
96	C.F.R. 1/4W J	330 KΩ	ea	1	R15		
97	FUSE	800 mA / 250 V	ea	2	F1		
98	FUSE	20 A / 250 V	ea	1	F2		
99	FUSE CLIP	1A3399-10	ea	2			2 A
100	FUSE CLIP	1A1119-10	ea	2			20 A

MATERIAL PART- LIST

Model : M 3830

Date : Dec. 21, 1993

NO	N A M E	RATINGS & DIMENSION	UNIT	Q'TY	PART NO.	자재코드	REMARKS
101	M.N.W.R. 1W	4.5 Ω	ea	1	R66		CURRENT RESISTOR
102	M.N.W.R. 1W	0.5 Ω	ea	1	R67		"
103	M.N.P.R. 10W	0.005 Ω	ea	1	R68		"
104	DIODE (L.E.D)	251GC	ea	4	D26 ~ D29		BACK LIGHTING
105	GROUND POLE	φ 6 × 4.0	ea	1			
106	C. SOCKET PIN	M 3850	ea	2			
107	I.C. SOCKET	9 PIN	ea	1			
108	I.C. SOCKET	7 PIN	ea	1			
109	I.C. SOCKET	3 PIN	ea	1			
110	CONNECTOR PIN	9 PIN	ea	1			9 mm
111	CONNECTOR PIN	7 PIN	ea	1			9 mm
112	CONNECTOR PIN	3 PIN	ea	1			9 mm
113	CONNECTOR PIN	5 PIN	ea	1			10 mm
114	BATTERY SNAP	180 mm	ea	1			
115	L. C. D.	LS-0912D	ea	1			
116	FRONT CASE	84 × 187 × 24t	ea	1			
117	BACK CASE	84 × 187 × 19t	ea	1			
118	KNOB	45 φ	ea	1			
119	POWER S/W KNOB	M 3270	ea	1			RED
120	BATTERY COVER		ea	1			
121	STAND	M 3850	ea	1			
122	JACK TERMINAL MOLD	RED	ea	3			
123	JACK TERMINAL MOLD	BLACK	ea	1			
124	BACK LIGHTING BOARD	66.1 × 33.8 × 2t	ea	1			

MATERIAL PART- LIST

Model : M 3830

Date : Dec. 21, 1993

NO	N A M E	RATINGS & DIMENSION	UNIT	Q'TY	PART NO.	자재코드	REMARKS
125	REFLECTIVE BOARD	70.2 x 37.6 x 3.2t	ea	1			
126	S/W RUBBER GUIDE	54.5 x 12.6 x 1.5t	ea	1			
127	SELECTOR	M 3270	ea	1			
128	KEY RUBBER	A	ea	1			
129	KEY RUBBER	B	ea	1			
130	RUBBER FOOT	LARGE	ea	1			BACK
131	RUBBER FOOT	SMALL	ea	1			BATTERY COVER
132	GASKET	M 3830	ea	1			
133	SHIELD PAPER	250 V / 800 mA	ea	1			
134	FRONT PANEL(S/W)	69.5 x 14.7 x 0.4t	ea	1			
135	PCB SUPPCRT	φ 5.0 x 8.0	ea	1			
136	E. RING	φ 5	ea	1			
137	BALL	φ 4.0 ( φ 3.96 )	ea	2			
138	COIL SPRING A	외경 3.85 자유장 7.5	ea	1	6 TURN		선지름 : 0.5 φ
139	COIL SPRING B	외경 3.85 자유장 6.0	ea	1	5 TURN		선지름 : 0.5 φ
140	INTER CONNECTOR A	69.5 x 23.7 x 1.8t	ea	1			
141	INTER CONNECTOR B	69.5 x 18.8 x 1.8t	ea	1			
142	SCREW BOLT	φ 3.0 x 21.0	ea	4			FRONT CASE
143	SCREW BOLT	φ 2.6 x 10.5	ea	1			BATTERY COVER
144	SCREW BOLT	φ 3 x 4.0	ea	5			LCD BASE / 상·하 조립
145	SCREW BOLT	φ 2 x 5.0	ea	3			S/W GUIDE
146	SCREW BOLT	φ 2.6 x 4	ea	1			SHIELD PAPER 용
147	SUPPORT NUT	3.0 φ	ea	1			
148	SHIELD WIRE	40 mm	ea	1			
149	LEAD WIRE	0.12 x 7 십 50 mm	ea	1			BLACK



MATERIAL PART LIST

Model : M 3830

Date : Dec. 21, 1993

NO	N A M E	RATINGS & DIMENSION	UNIT	Q'TY	PART NO.	자재코드	REMARKS
150	LEAD WIRE	0.12 x 7 침 80 mm	pair	1			RED / BLACK
151	LCD BASE	GP-GLASS	ea	1			
152	WINDOW	M 3850	ea	1			P.C.
153	RS232C PLUG	6 PIN (MT/RS232C)	ea	1			
154	SELECTOR SHAFT	M 3270	ea	1			
155	FRONT CASE INSERT A	φ 5.0 x 6.4	ea	2			
156	FRONT CASE INSERT B	φ 5.0 x 10.4	ea	2			
157	BACK CASE INSERT	φ 4.0 x 5	ea	1			
158	LCD BASE INSERT	φ 5.0 x 10.0	ea	4			
159	AIR BAG		ea	1			
160	SPONGE	16.0 x 50.0 x 10.0t	ea	1			
161	CONTACTOR		ea	4			
162	TEST LEAD	RED/BLACK	pair	1			
163	BATTERY	9 V (FC-1)	ea	1			
164	CARRYING CASE	M3830	ea	1			
165	GIFT BOX	M3830	ea	1			
166	MANUAL	M3830	ea	1			
167	PROGRAMED FLOPPY DISK	5.25 INCH (2D)	ea	1			* OPTION
168	~	3.5 INCH (2HD)	ea	1			* OPTION
169	SOLDER	1.2 φ x 60 %	g	20			



# MATERIAL PART LIST

For M-3850

ITEM NO.	NO.	NAME	DESCRIPTION	CONTENTS	REVISED	REMARKS
1	12	OP07	IC16, IC10	→	IC10, IC15	REV
2	13	P.C.B.	155.5 × 73.0	→	155.5 × 73.0 × 1.6t	REV
3	14	P.C.B.	37.0 × 73.0	→	37.0 × 73.0 × 1.6t	REV
4	15	P.C.B.	70.1 × 36.6	→	70.1 × 36.6 × 1.6t	REV
5	16	L.C.D.	S-0912D	→	LS-0912D	REV
6	25	SW. DIODE	4ea	→	3ea	DEC
7	26	REC. DIODE	4007	→	IN4007	REV
8	30	TRANSISTOR	A733/BF909/BF910	→	A733(KTA1504S)	REV
9	31	TRANSISTOR	C3121	→	KTC3121RTK	REV
10	44	M.D.V.R.	500 KΩ	→	300 KΩ	REV
11	45	M.D.V.R.	2 KΩ	→	500 Ω	REV
12	49	JACK TERMINAL	M-3850	→	16.0 × 5 φ	REV
13	68	FUSE CLIP	P.C.B. TYPE	→	1A3399-10	REV
14	69	FUSE CLIP	P.C.B. TYPE	→	1A1119-10	REV
15	72	M.N.W.R. 1W	4.5 / 1W	→	4.5	REV
16	73	M.N.W.R. 1W	0.5 / 1W	→	0.5	REV

※ 생산 1과 운 안재 기사의 요청에 의하여 수정함.

NO : 3rd REV.  
 MODEL : M - 3850  
 DATE : Dec. 28, 1993.  
 PAGE : 8

CHARGE	CHECKED	APPROVED
		

## MATERIAL PART LIST

MODEL : M-3850

DATE : Dec. 28, 1993

ITEM NO.	NO.	N A M E	DESCRIPTION	CONTENTS	REVISED	REMARKS
17	74	M.N.P.R. 10W	0.005 / 10W	→ 0.005		REV
18	80	E. C.	T. C.			REV
19	86	C.F.R. ¼W J	1 KΩ	→ 1.3 KΩ		REV
20	87	C.F.R. ¼W J	25ea	→ 26ea		INC
21	89	C.F.R. ¼W J	2ea	→ 1ea		DEC
22	91	C.F.R. ¼W J	7.5 K	1ea → 3ea		INC
23	92	C.F.R. ¼W J	10K	7ea → 6ea		DEC
24	93	C.F.R. ¼W J	2 K	1ea		INS
25	99	C.F.R. W J	100 KΩ	→ 560 Ω		REV
26	108	CERAMIC CAP	9ea	→ 10ea		INC
27	109	CERAMIC CAP	3ea	→ 2ea		DEC
28	112	CERAMIC CAP	1ea	→ 2ea		INC
29	130	KEY RUBBER	M 3270	→ A		REV
30	131	KEY RUBBER	M 3850	→ B		REV
31	134	SHIELD PAPER	M 3850	→ 250 V / 800 mA		REV
32	157	6각 봉	3 φ	→ 110 mm 1pair		DEL
33	156	TEST LEAD	RED/BLACK	1pair		INS
34	158	TEMP PLUG	1ea			DEL
35	158	RUBBER FOOT	M 36B	→ LAGRE		REV
36	159	RUBBER FOOT	M 3850	→ SMALL		REV
37	165	TEMP SOCKET INSERT	3ea	→ 2ea		DEC
38	168	JACK TERMINAL MOLD	4ea	→ 3ea		DEC
39	169	JACK TERMINAL MOLD	BLACK	1ea		INS

MATERIAL PART LIST

MODEL : M-3850

DATE : Dec. 28, 1993

ITEM NO.	NO.	N A M E	DESCRIPTION	CONTENTS	REVISED	REMARKS
40	170	MANUAL	M 3850	1ea		INS
41	171	THERMECOUPLER WIRE	K24/1/304	1ea		INS
42	172	ALUMEL	STRIPS ON COIL	0.64g		INS
43	173	CHROMEL	STRIPS ON COIL	0.55g		INS
41	174	PROGRAMED FLOPPY DISK	5.25 INCH (2D)	1ea		INS
42	175	PROGRAMED FLOPPY DISK	3.5 INGH (2HD)	1ea		INS
43	176	BATTERY	9 V (FC-1)	1ea		INS
44	177	CARRYING CASE	M3850	1ea		INS
45	178	GIFT BOX	M 3850	1ea		INS
46	179	SOLDER	1.2 $\phi$ x 60 %	20g		INS
47	180	SPONGE	1ea			INS
48	181	PUSH KNOB	1ea	RED		INS
49	182	CONTACTOR	4ea			INS

MATERIAL PART LIST

Model : M-3850

Date : Dec. 28, 1993

NO	N A M E	RATINGS & DIMENSION	UNIT	Q'TY	PART NO.	자재코드	REMARKS
1	C. P. U.	92DM (820-54)	ea	1	IC1		S.M.D TYPE (80 PIN)
2	C. P. U.	92DS (820-56)	ea	1	IC2		S.M.D TYPE (80 PIN)
3	L. S. I.	MAX134 CMH	ea	1	IC3		S.M.D TYPE (44 PIN)
4	I. C.	TL062	ea	2	IC7,8		S.M.D TYPE (8 PIN)
5	I. C.	CD4027	ea	1	IC9		S.M.D TYPE (16 PIN)
6	I. C.	CD4011	ea	1	IC4		S.M.D TYPE (14 PIN)
7	I. C.	CD4066	ea	1	IC5		S.M.D TYPE (14 PIN)
8	I. C.	ICM7555	ea	1	IC6		S.M.D TYPE (8 PIN)
9	I. C.	9005	ea	1	IC13		S.M.D TYPE D.I.P TYPE (20 PIN)
10	I. C.	PC817	ea	2	IC11,12		DIP TYPE (4 PIN)
11	HYBRID I. C.	HD-08	ea	1	IC14		
12	I. C.	OP07	ea	2	IC10,IC15		DIP TYPE (8 PIN)
13	P. C. B.	155.5 x 73.0 x 1.6t	ea	1			MAIN
14	P. C. B.	37.0 x 73.0 x 1.6t	ea	1			SUB
15	P. C. B.	70.1 x 36.6 x 1.6t	ea	1			BACK LIGHTING
16	L. C. D.	LS-0912D	ea	1			
17	CRYSTAL	32.768 KHz	ea	1	XT1		SMALL TYPE
18	CRYSTAL	38.400 KHz	ea	2	XT2,3		
19	CRYSTAL	4.1856 MHz	ea	1	XT4		
20	ARRAY RES	6 PIN 100 K	ea	1	RA1		BECKMAN
21	ARRAY RES	9 PIN 100 K	ea	1	RA2		BECKMAN
22	POSISTOR	1.5 K	ea	2	PTC1,2		
23	SW. DIODE	KDS 184	ea	5	D1,2,3,4,5		B3 (SMD TYPE)
24	SW. DIODE	KDS 193/ KDS 196	ea	11	D6 ~ D16		F3/G3 (SMD TYPE)
25	SW. DIODE	KDS 226	ea	3	D17,18,19		C3 (SMD TYPE)

MATERIAL PART LIST

Model : M-3850

Date : Dec. 28, 1993

NO	N A M E	RATINGS & DIMENSION	UNIT	Q'TY	PART NO.	자재코드	REMARKS
26	REC. DIODE	1N4007	ea	9	D20 - D28		
27	REF. DIODE	1.2 V ( BJ04 )	ea	1	D29		
28	TRANSISTOR	MPSA42 (MMBTA42)	ea	2	Q1,2		S.M.D TYPE (AAX)
29	TRANSISTOR	C945 (KTC3875SY)	ea	4	Q3,8,9,10		S.M.D TYPE (ALY)
30	TRANSISTOR	A733 (KTA1504S)	ea	2	Q5,Q6		S.M.D TYPE (ASY)
31	TRANSISTOR	KTC3121RTK	ea	1	Q4		S.M.D. TYPE (VA)
32	F. E. T.	K192A	ea	1	Q7		
33	M.P.F.C.	223 ( 0.022 )	ea	2	C28,29		SMALL BOX TYPE
34	M.P.F.C.	472 ( 0.0047 )	ea	1	C25		SMALL BOX TYPE
35	M.P.F.C.	104 / 63 WV	ea	1	C26		SMALL BOX TYPE
36	M.P.F.C.	224 / 63 WV	ea	1	C27		SMALL BOX TYPE
37	BUZZER	PIEZO BUZZER	ea	1	BZ1		
38	PUSH SWITCH	2C2P SELF LOCK	ea	1	SW 1		PLT-2201
39	M.G.V.R.	5 K $\Omega$	ea	1	VR1		TEMP 조정용
40	M.D.V.R.	200 $\Omega$	ea	1	VR2		AC GAIN 조정용
41	M.G.V.R.	500 $\Omega$	ea	1	VR3		REFERENCE 조정용
42	M.D.V.R.	20 K $\Omega$	ea	1	VR4		AC ZERO 조정용
43	M.G.V.R.	100 K $\Omega$	ea	1	VR5		DC VOLT GAIN
44	M.D.V.R.	300 K $\Omega$	ea	1	VR6		CAP 조정용 (20W)
45	M.D.V.R.	500 $\Omega$	ea	1	VR7		CAP 조정용 (HIGH)
46	M.D.V.R.	5 K $\Omega$	ea	1	VR8		ROOM TEMP. 조정용
47	TR SOCKET	8 PIN ROUND TYPE	ea	1			
48	HOUSING	RS - 232C MOLEX	ea	1			6 PIN
49	JACK TERMINAL	16.0 x 5 $\phi$	ea	4			
50	M.F.R. 1/2 W D	10 M $\Omega$	ea	1	R69		

MATERIAL PART LIST

Model : M-3850

Date : Dec. 28, 1993

NO	N A M E	RATINGS & DIMENSION	UNIT	Q'TY	PART NO.	자재코드	REMARKS
51	M.F.R. 1/2W D	9.95 MΩ	ea	1	R70		
52	M.F.R. 1/4W D	1.111 MΩ	ea	1	R71		
53	M.F.R. 1/4W D	101.01 KΩ	ea	1	R72		
54	M.F.R. 1/4W D	10.01 KΩ	ea	1	R73		
55	M.F.R. 1/4W D	1.000 KΩ	ea	1	R74		
56	M.F.R. 1/4W D	1.2 MΩ	ea	1	R75		
57	M.F.R. 1/4W D	301 KΩ	ea	2	R76,R77		
58	M.F.R. 1/4W D	1 MΩ	ea	1	R78		
59	M.F.R. 1/4W D	5.62 KΩ	ea	2	R79,R80		
60	M.F.R. 1/4W D	19.32 KΩ	ea	1	R81		
61	M.F.R. 1/4W D	13.35 KΩ	ea	1	R82		
62	M.F.R. 1/4W D	1.8 MΩ	ea	1	R83		
63	M.F.R. 1/4W F	75 Ω	ea	1	R85		
64	M.F.R. 1/4W F	5.19 KΩ	ea	1	R84		
65	C.F.R. 1/4W J	330 KΩ	ea	1	R65		
66	FUSE	800 mA / 250 V	ea	2	F1		
67	FUSE	20 A / 250 V	ea	1	F2		
68	FUSE CLIP	1A3399-10	ea	2			2 A
69	FUSE CLIP	1A1119-10	ea	2			20 A
70	DIODE (L.E.D)	251GC	ea	4	D30 ~ D33		BACK LIGHTING
71	SURGE. CAP	102 / 1 KV	ea	1	C30		
72	M.N.W.R 1W	4.5 Ω	ea	1	R66		CURRENT RESISTOR
73	M.N.W.R 1W	0.5 Ω	ea	1	R67		"
74	M.N.P.R 10 W	0.005 Ω	ea	1	R68		"
75	E. C.	0.33 uF	ea	2	C31,C32		

MATERIAL PART LIST

Model : M-3850

Date : Dec. 28, 1993

NO	NAME	RATINGS & DIMENSION	UNIT	Q'TY	PART NO.	자재코드	REMARKS
76	E. C.	1.0 uF	ea	1	C33		
77	E. C.	10 uF	ea	1	C37		
78	E. C.	47 uF	ea	2	C34, C35		
79	E. C.	22 uF	ea	1	C36		
80	T. C.	4.7 uF	ea	1	C38		
81	T. C.	0.33 uF ( 334 )	ea	1	C39		
82	I. C. SOCKET	14 PIN	ea	1			28 PIN ( 1/2 EA)
83	I. C. SOCKET	9 PIN	ea	1			18 PIN ( 1/2 EA)
84	I. C. SOCKET	4 PIN	ea	1			8 PIN ( 1/2 EA)
85	C.F.R. 1/4W J	150 Ω	ea	4	R1 ~ R4		CHIP TYPE
86	C.F.R. 1/4W J	1.3 KΩ	ea	1	R58		CHIP TYPE
87	C.F.R 1/4W J	100 KΩ	ea	25	R5, R24, R26~R30		CHIP TYPE
88	C.F.R 1/4W J	330 KΩ	ea	2	R60, R61		CHIP TYPE
89	C.F.R 1/4W J	750 Ω	ea	1	R31		CHIP TYPE
90	C.F.R 1/4W J	3.3 KΩ	ea	2	R32, R33		CHIP TYPE
91	C.F.R 1/4W J	7.5 KΩ	ea	3	R34, R44, R49		CHIP TYPE
92	C.F.R 1/4W J	10 KΩ	ea	6	R35, 37~41		CHIP TYPE
93	C.F.R 1/4W J	2 KΩ	ea	1	R36		CHIP TYPE
94	C.F.R 1/4W J	5.6 KΩ	ea	1	R50		CHIP TYPE
95	C.F.R 1/4W J	2.2 MΩ	ea	3	R45, R46, R47		CHIP TYPE
96	C.F.R 1/4W J	51 KΩ	ea	1	R48		CHIP TYPE
97	C.F.R 1/4W J	390 KΩ	ea	1	R51		CHIP TYPE
98	C.F.R 1/4W J	200 KΩ	ea	2	R52, R53		CHIP TYPE
99	C.F.R 1/4W J	1 MΩ	ea	4	R54 ~ R57		CHIP TYPE
100	C.F.R 1/4W J	560 Ω	ea	1	R59		CHIP TYPE



MATERIAL PART LIST

MODEL : M-3850

DATE : Dec. 28, 1993

NO	N A M E	RATINGS & DIMENSION	UNIT	Q'TY	PART NO.	자재코드	REMARKS
101	C.F.R 1/4W J	160 KΩ	ea	1	R62		CHIP TYPE
102	C.F.R. 1/4W J	56 KΩ	ea	1	R25		CHIP TYPE
103	C.F.R. 1/4W J	910 KΩ	ea	2	R63,R64		CHIP TYPE
104	C.F.R. 1/4W F	3 KΩ	ea	1	R42		CHIP TYPE
105	C.F.R. 1/4W F	3.6 KΩ	ea	1	R43		CHIP TYPE
106	CERAMIC CAP	10 P	ea	1	C1		CHIP TYPE
107	CERAMIC CAP	221	ea	2	C3,4		CHIP TYPE
108	CERAMIC CAP	104	ea	10	C5 ~ C14		CHIP TYPE
109	CERAMIC CAP	103	ea	2	C15,C16		CHIP TYPE
110	CERAMIC CAP	33 P	ea	2	C17,18		CHIP TYPE
111	CERAMIC CAP	22 P	ea	4	C19~C22		CHIP TYPE
112	CERAMIC CAP	683	ea	2	C23,C24		CHIP TYPE
113	CERAMIC CAP	100 p	ea	1	C2		CHIP TYPE
114	CONNECTOR PIN	14 PIN	ea	1			9 mm
115	CONNECTOR PIN	9 PIN	ea	1			9 mm
116	CONNECTOR PIN	4 PIN	ea	1			10 mm
117	C SOCKET PIN	M 3850	ea	2			
118	GROUND POLE	φ 6 × 4.0	ea	1			
119	BATTERY SNAP	180 mm	ea	1			
120	FRONT CASE	84.0 × 187.0 × 24t	ea	1			
121	BACK CASE	84.0 × 187.0 × 19t	ea	1			
122	KNOB	45 φ	ea	1			
123	POWER S/W KNOB	M 3270	ea	1			RED
124	BATTERY COVER		ea	1			
125	STAND	M 3850	ea	1			

MATERIAL PART LIST

Model : M-3850

Date : Dec. 28, 1993

NO	N A M E	RATINGS & DIMENSION	UNIT	Q'TY	PART NO.	자재코드	REMARKS
126	BACK LIGHTING BOARD	66.1 x 33.8 x 2t	ea	1			
127	REFLECTIVE BOARD	70.2 x 37.6 x 3.2t	ea	1			
128	S/W RUBBER GUIDE	54.4 x 12.6 x 1.5t	ea	1			
129	SELECTOR	M 3850	ea	1			
130	KEY RUBBER	A	ea	1			
131	KEY RUBBER	B	ea	1			
132	GASKET	M 3850	ea	1			
133	SHIELD PAPER	250 V / 800 mA	ea	1			
134	E RING	φ 5.0	ea	1			
135	BALL	φ 4.0 (φ 3.96)	ea	2			
136	COIL SPRING A	외경 3.85, 자유장 7.5	ea	1	6 TURN		선지름 : 0.5 φ
137	COIL SPRING B	외경 3.85, 자유장 6.0	ea	1	5 TURN		선지름 : 0.5 φ
138	INTER CONNECTOR A	69.5 X 23.7 X 1.8t	ea	1			
139	INTER CONNECTOR B	69.5 X 18.8 X 1.8t	ea	1			
140	SCREW BOLT	φ 3.0 X 21.0	ea	4			FRONT CASE
141	SCREW BOLT	φ 2.6 X 10.5	ea	1			BATTERY COVER
142	SCREW BOLT	φ 3x4.0	ea	5			LCD BASE/상·하 조립
143	SCREW BOLT	φ 2x5.0	ea	3			S/W GUIDE
144	SCREW BOLT	M 2.6 X 4	ea	1			SHIELD PAPER 용
145	NUT	M3x5.0, 3.0 φ	ea	1			
146	SCREW BOLT	M2.6 X 7.0	ea	3			
147	SCREW BOLT	M2.6 X 3.0	ea	2			
148	SHIELD WIRE	40 mm	ea	1			
149	LEAD WIRE	0.12 x 10 50 mm	ea	1			BLACK
150	LEAD WIRE	0.12 x 10 8cm	pair	1			RED/BLACK

MATERIAL PART LIST

Model : M-3850

Date : Dec. 28, 1993

NO	N A M E	RATINGS & DIMENSION	UNIT	Q' TY	PART NO.	자재코드	REMARKS
151	LCD BASE	GP-GLASS	ea	1			
152	WINDOW		ea	1			PC
153	S/W PANEL	69.5x14.7x0.4t	ea	1			
154	AIR BAG		ea	1			
155	TEST LEAD	RED / BLACK	pair	1			
156	RS232C CABLE	6 PIN	ea	1			MT/RS232C
157	RUBBER FOOT	LARGE	ea	1			BACK
158	RUBBER FOOT	SMALL	ea	1			BATTERY COVER
159	SELECTOR SHAFT		ea	1			
160	FRONT CASE INSERT A	φ 5.0 X 6.4	ea	2			
161	FRONT CASE INSERT B	φ 5.0 X 10.4	ea	2			
162	BACK CASE INSERT	φ 4.0 X 5	ea	1			
163	LCD BASE INSERT	φ 5.0 X 10.0	ea	4			
164	TEMP SOCKET INSERT	φ 4.5 X 2.7	ea	2			
165	PCB SUPPORT	φ 5.0 X 8.0	ea	1			
166	TEMP SOCKET , NUT	φ 2.6	ea	3			
167	JACK TERMINAL MOLD	RED	ea	3			
168	JACK TERMINAL MOLD	BLACK	ea	1			
169	MANUAL	M 3850	ea	1			
170	THERMECOUPLER WIRE	K24/I/304	ea	1			
171	ALUMEL	STRIPS ON COIL	g	0.54			BLACK
172	CHROMEL	"	g	0.55			RED
173	PROGRAMED FLOPPY DISK	5.25 INCH (2D)	ea	1			* OPTION
174	PROGRAMED FLOPPY DISK	3.5 INCH (2HD)	ea	1			* OPTION
175	BATTERY	9 V (FC - 1)	ea	1			

MATERIAL PART LIST

Model : M-3850

Date : Dec. 28, 1993

NO	N A M E	RATINGS & DIMENSION	UNIT	QTY	PART NO.	자재코드	REMARKS
176	CARRYING CASE	M 3850	ea	1			
177	GIFT BOX	M 3850	ea	1			
178	SOLDER	1.2 $\phi$ x 60 %	g	20			
179	SPONGE	50.0x16.0x10.0t	ea	1			
180	CONTACTOR		ea	4			
181							
182							
183							
184							
185							
186							
187							
188							
189							
190							
191							
192							
193							
194							
195							
196							
197							
198							
199							
200							

TECHNICAL DATA FOR DIGITAL MULTIMETER

MODEL: M-3850 & M-3830

1	2	3	4	5	6	7	8	9	10	11	12	13	14	15
M6	M5	M4	M3	M4	M5	M6	M9	M7	M5	M5	M5	M6	M5	M5
29	29	27	26	25	24	23	22	21	20	19	18	17	16	
57	M6	M6	M6	M6	M6	M6	M6	M6	M6	M7	M5	M5	M5	M5
30	31	32	33	34	35	36	37	38	39	40	41	42	43	44
S6	S6	S6	S6	S6	S6	S6	S6	S6	S6	S5	S5	S5	S5	S5
53	57	56	55	54	53	52	51	50	49	48	47	46	45	
M7	M7	M7	S3	S4	S5	S6			S7	S5	S5	S5	S5	S5

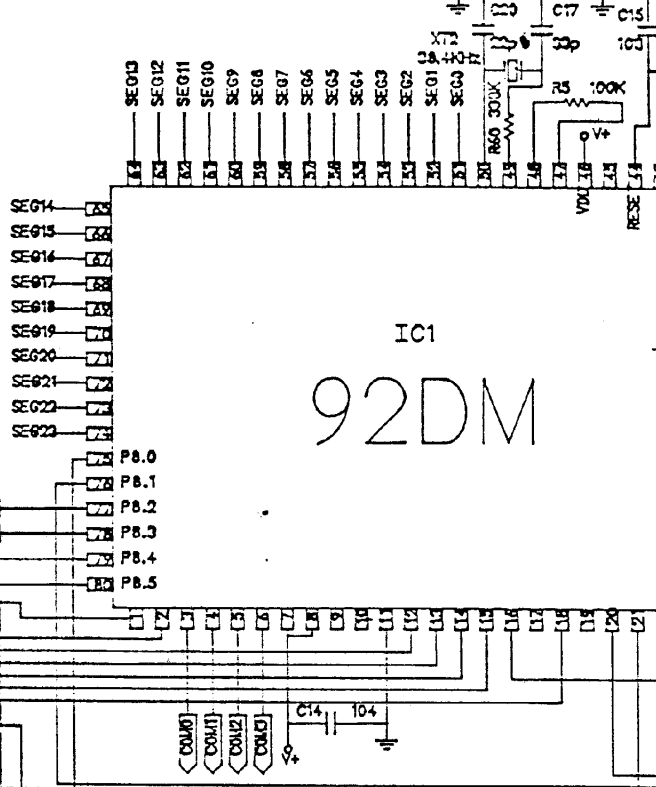

RANGE
0. mV
1. V
2. mA
3. A
4. OHM
5. DIODE
6. FREQ
7. CAP
8. hFE
9. TEMP
10. ROOM
11. LOGIC

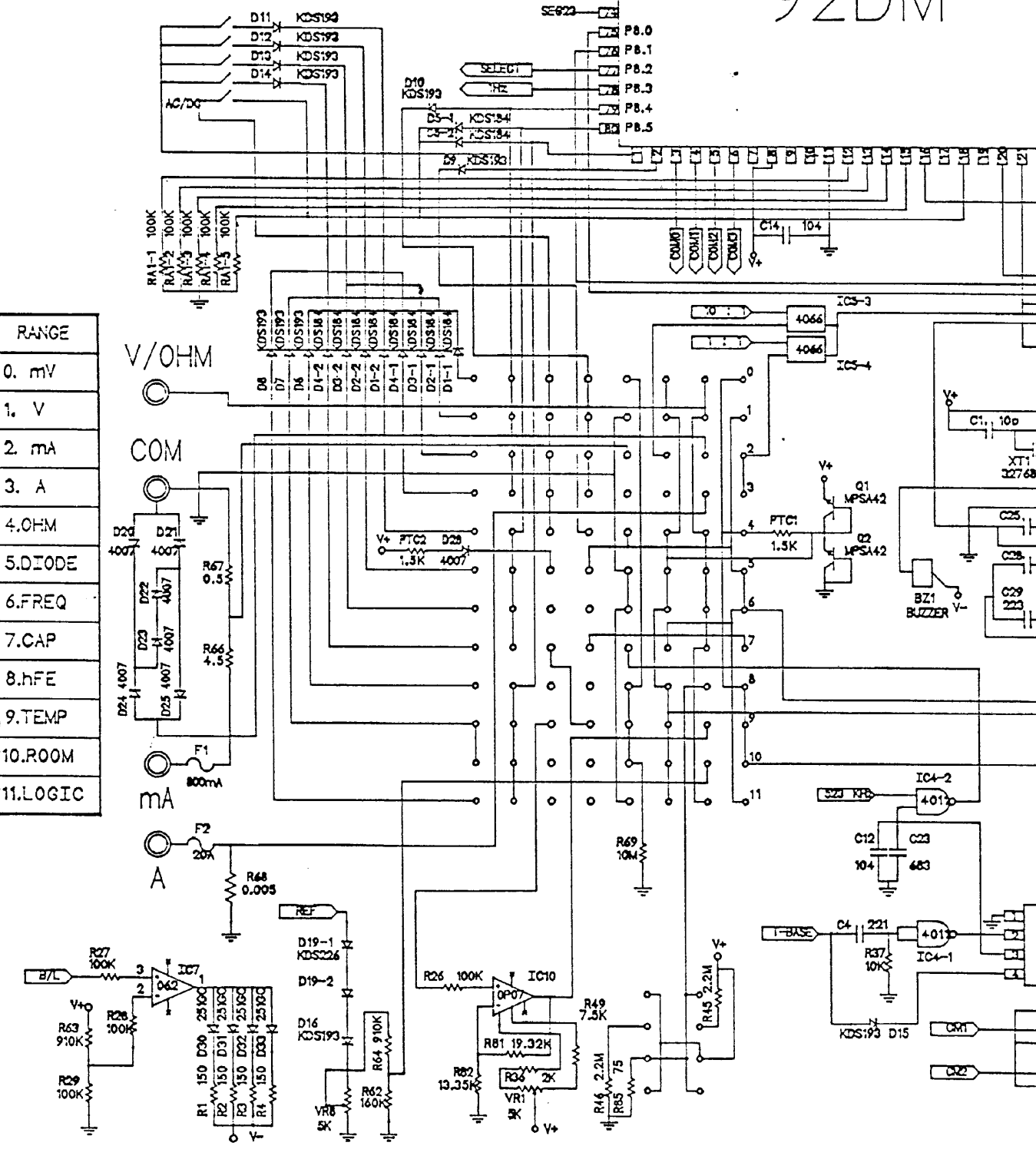

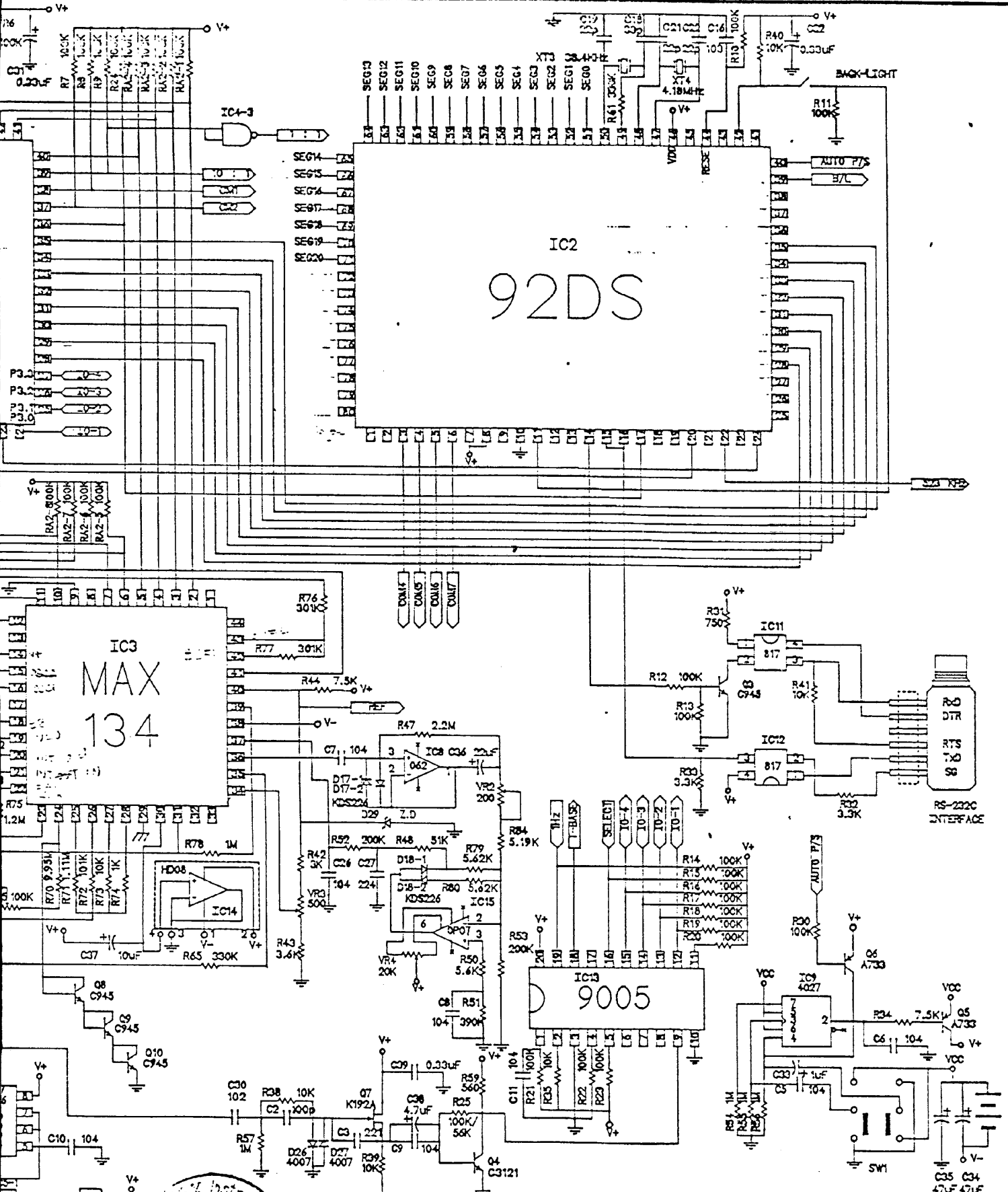

1004.3.03

REMARKS :

TITLE					
M-3850 SCHEMATIC DIAGRAM					
DRAWN	DESIGNED	CHECKED	APPROVED	DATE	1993.12.3
				DWG_NO	5 th
METEX INSTRUMENTS			MODEL	M-3850	

CALIBRATION PROCEDURE :

STEP	CONTROL SETTING	CONNECTION & INPUT	ADJUST	ADJUST FOR
1	Set the ON/OFF Switch ON.			
Adjustment of DC mill-Voltage Measurement Function.				
2	Function Range Switch: DC 400.0 mV	1) Connect DC mill-Voltage Calibrator. 2) Apply DC 390.0 mV to Input Terminal.	VR3(500 ohm)	Display reading within specification. Adjust VR3 so the display reads "390.0 mV".
Adjustment of AC mill-Voltage Measurement Function.				
3	Function Range Switch: AC 400.0 mV In use with DC/AC Switch	1) Connect AC mill-Voltage Calibrator. 2) Apply AC "000.0 mV" ( 50Hz ) to Input Terminal. 3) Apply AC "390.0 mV" ( 50Hz ) to Input Terminal.	VR4(20 Kohm)  VR2(200 ohm)	Display reading within specification. Adjust VR4 so the display reads "000.0 mV".  Adjust VR2 so the display reads "390.0 mV".
Adjustment of DC Voltage Measurement Function.				
4	Function Range Switch: DC Voltage	1) Connect DC Voltage Calibrator. 2) Apply DC "3.900 V" to Input Terminal. 3) Apply DC "39.00 V" to Input Terminal. 4) Apply DC "390.0 V" to Input Terminal. 5) Apply DC "990 V" to Input Terminal.	VR5(100 Kohm)	Display reading within specification. Adjust VR5, R71 so the display reads "3.900 V". Adjust R72 so the display reads "39.00 V". Adjust R73 so the display reads "390.0 V". Adjust R74 so the display reads " 990 V".
Adjustment of AC Voltage Measurement Function.				
5	Function Range Switch: AC Voltage In use with DC/AC Switch	1) Connect AC Voltage Calibrator. 2) Apply AC "0.000 V" (50Hz) to Input Terminal 2) Apply AC "3.900 V" to (50Hz) to Input Terminal 3) Apply AC "39.00 V" to (50Hz) to Input Terminal 4) Apply AC "390.0 V" to (50Hz) to Input Terminal 5) Apply AC " 700 V" to (50Hz) to Input Terminal	VR4(20 Kohm)  VR5(100 Kohm )	Display reading within specification. Adjust VR4 so the display reads "0.000 V". Adjust VR5, R71 so the display reads "3.900 V". Adjust R72 so the display reads "39.00 V". Adjust R73 so the display reads "390.0 V". Adjust R74 so the display reads " 700 V".
Adjustment of DC 400 mA Measurement Function.				
6	Function Range Switch: DC 400 mA	1) Connect DC Current Calibrator to Input(mA), Input (COM) Terminal. 2) Apply "20.00 mA" to Input Terminal. 3) Apply "200.0 mA" to Input Terminal.		Display reading within specification.  Adjust R87 so the display reads "20.00 mA". Adjust R88 so the display reads "200.0 mA".
Adjustment of AC 400 mA Measurement Function.				
7	Function Range Switch: AC 400 mA In use with DC/AC Switch	1) Connect AC Current Calibrator to Input(mA), Input (COM) Terminal. 2) Apply AC "0.000 V" (50Hz) to Input Terminal 2) Apply "20.00 mA" to Input Terminal. 3) Apply "200.0 mA" to Input Terminal.	VR4(20 Kohm)	Display reading within specification.  Adjust VR4 so the display reads "00.00 mA". Adjust R87 so the display reads "20.00 mA". Adjust R88 so the display reads "200.0 mA".



STEP	CONTROL SETTING	CONNECTION & INPUT	ADJUST	ADJUST FOR
8	Adjustment of DC 20A Measurement Function			
	Function Range Switch: DC 20A	1) Connect DC Current Calibrator to Input(20A) and Input(COM) Terminal. 2) Apply DC "1.00 A" to Input Terminal.		Display reading within Specification. Adjust R88 so the display reads " 1.00 A".
9	Adjustment of AC 20A Measurement Function			
	Function Range Switch: AC 20A In use with DC/AC Switch	1) Connect DC Current Calibrator to Input(20A) and Input(COM) Terminal. 2) Apply AC "00.00 A"(50Hz) to Input Terminal 3) Apply AC "1.00 A"(50Hz) to Input Terminal.	VR4(20 Kohm)	Display reading within Specification. Adjust VR4 so the display reads "00.00 A". Adjust R88 so the display reads " 1.00 A".
10	Adjustment of Resistance Measurement Function			
	Function Range Switch: Resistance	1) Insert the standard Resistor to Input Terminal. 2) Insert "20.00 Mohm " Resistor to Input Terminal. 3) Insert "2.000 Mohm " Resistor to Input Terminal. 4) Insert "200.0 Kohm " Resistor to Input Terminal. 5) Insert "20.00 Kohm " Resistor to Input Terminal. 6) Insert "2.000 Kohm " , Resistor to Input Terminal. 7) Insert "200.0 ohm " Resistor to Input Terminal.		Display reading within specification. Adjust VR5, R70 so the display reads "20.00 Mohm". Adjust VR5, R70 so the display reads "2.000 Mohm". Adjust R71 so the display reads "200.0 Kohm". Adjust R72 so the display reads "20.00 Kohm". Adjust R73 so the display reads "2.000 Kohm". Adjust R74 so the display reads "200.0 ohm".
11	Adjustment of Capacitance Measurement Function			
	Function Range Switch: Capacitance	1) Insert the standard Capacitor into Socket on the left side : 2) Insert the Capacitor. ( 1pF - 400.0 nF ) 3) Insert the Capacitor. ( 1nF - 400.0 uF )	VR6(500 Kohm) VR7(2 Kohm)	Display reading within specification. Adjust VR6 so the display value within specification. Adjust VR7 so the display value within specification.
12	Adjustment of Temperature Measurement Function			
	Function Range Switch: Temperature	1) Connect Temperature Calibrator to Temperature socket on the left side. 2) Apply "100 C" to Temperature socket. 3) Apply "1200 C" to Temperature socket.	VR1(5 Kohm)	Display reading within specification. Adjust VR1 so the display reads "100 C". Adjust R81,R82 so the display reading within specification.
13	Adjustment of Room Temperature Measurement Function			
	Function Range Switch: Room Temperature	See the display readings is correct.	VR8(5 Kohm)	Adjust VR8 so the display reading is correct.

REMARKS :	TITLE M-3850 CALIBRATION PROCEDURE					
	DRAWN	DESIGNED	CHECKED	APPROVED	DATE	1993.5.8
					DWG. NO	
	METEX INSTRUMENTS				MODEL	M-3850 & M-3830

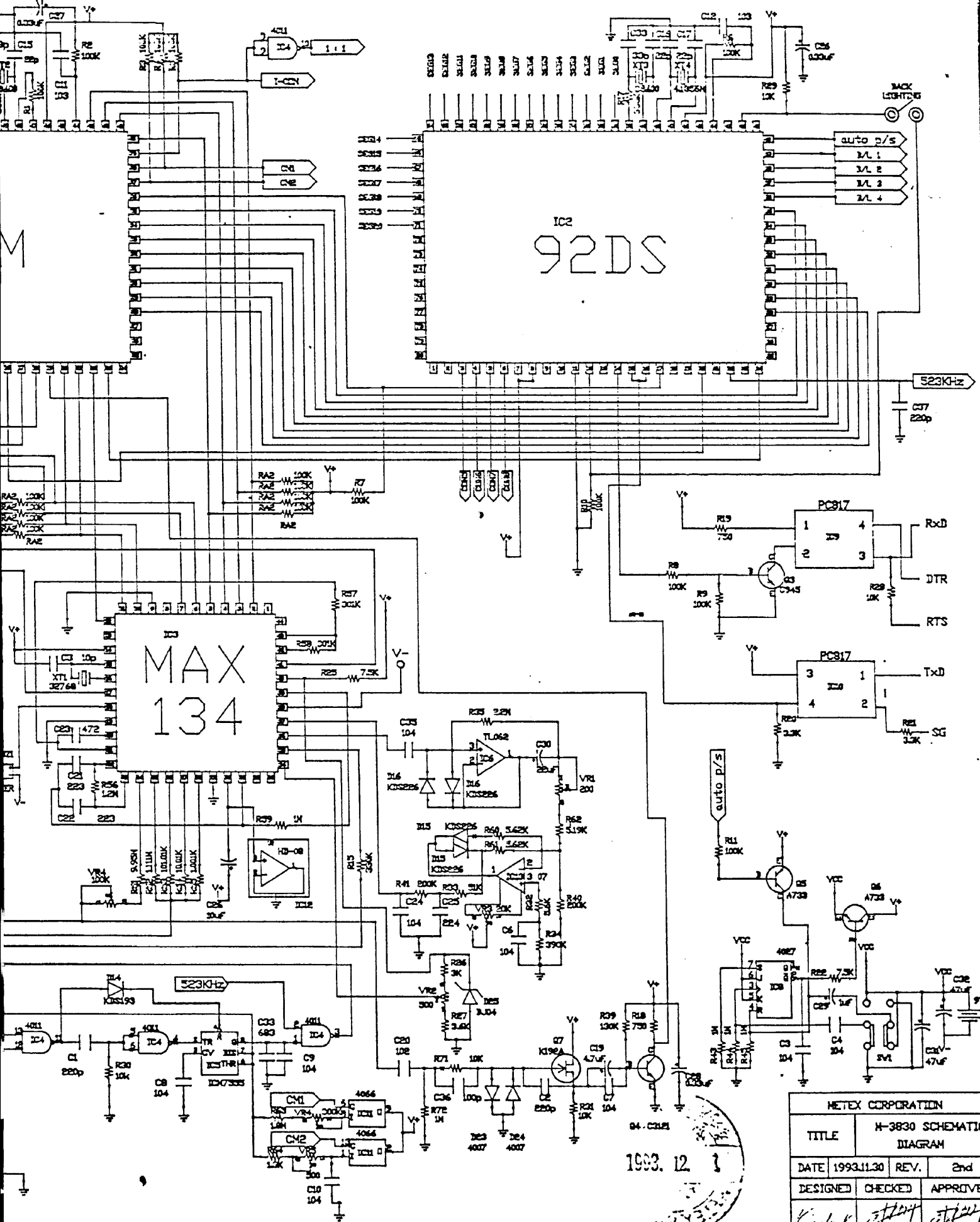

1993. 12

METEX CORPORATION			
TITLE	M-3830 SCHEMATIC DIAGRAM		
DATE	1993.11.30	REV.	2nd
DESIGNED	CHECKED	APPROVED	
<i>[Signature]</i>	<i>[Signature]</i>	<i>[Signature]</i>	

DM92

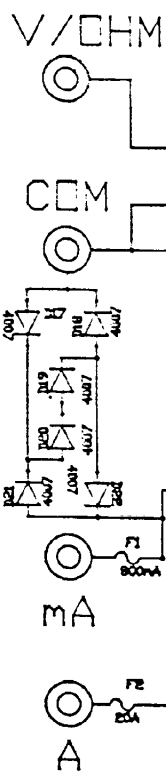
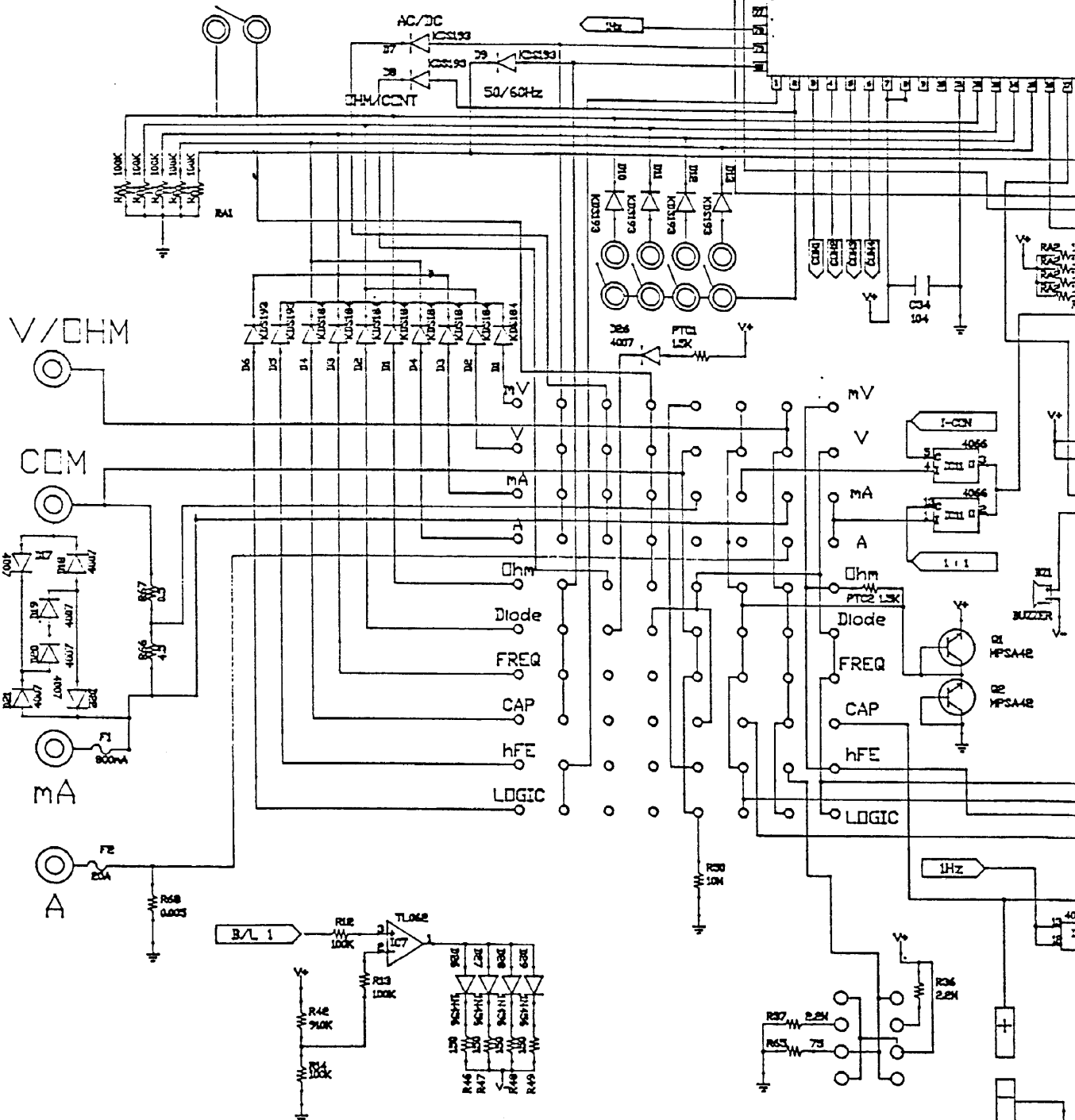
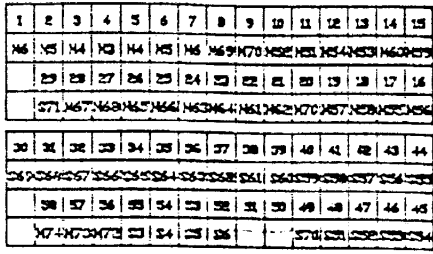
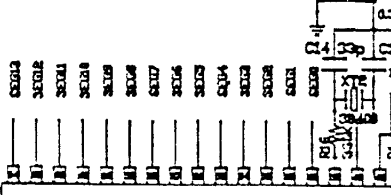

DC 400 mV RANGE

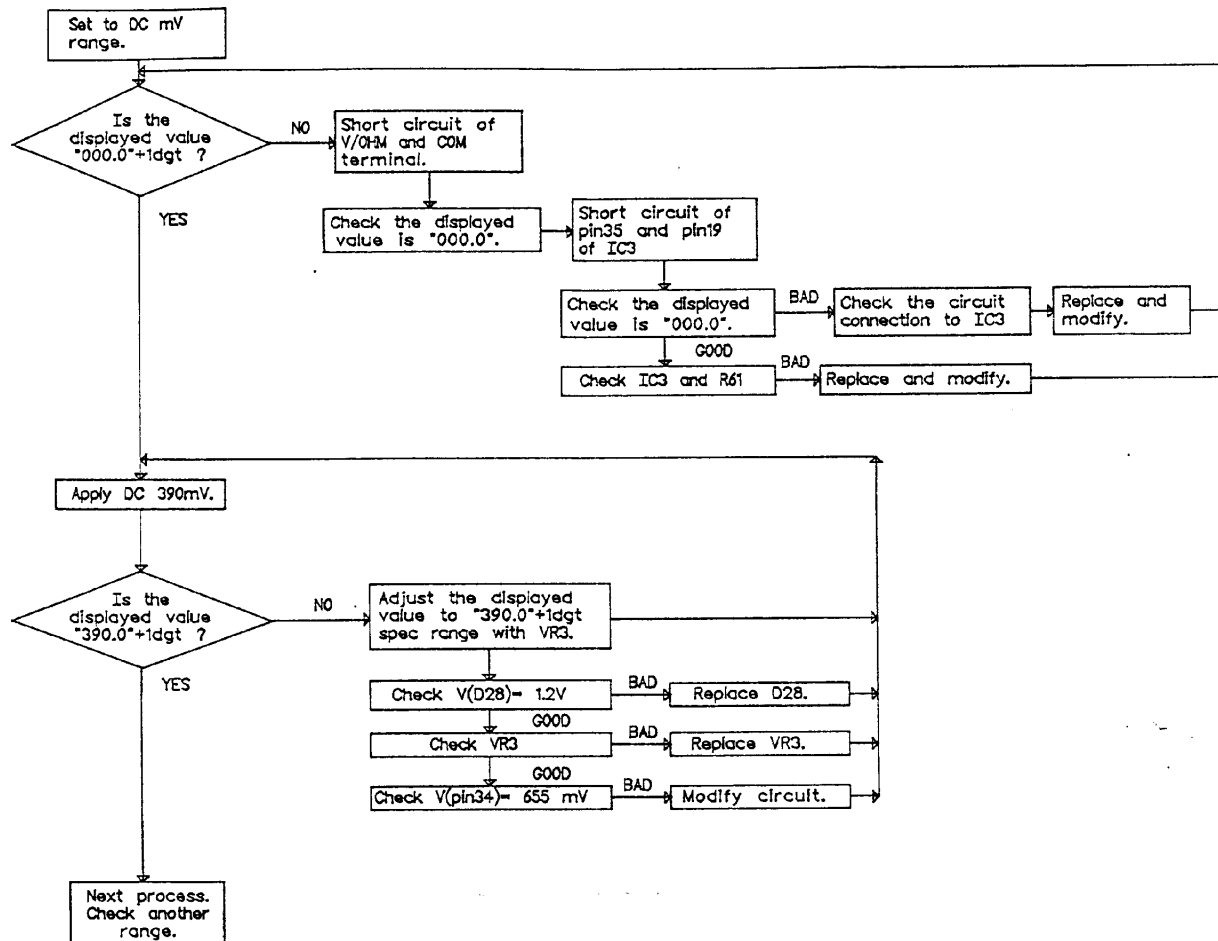

REMARKS :	TITLE DC mV RANGE TROUBLE SHOOTING				
	DRAWN	DESIGNED	CHECKED	APPROVED	DATE 1993.5.6
					DWG. NO 2
	METEX INSTRUMENTS				MODEL M-3850 & M-3830

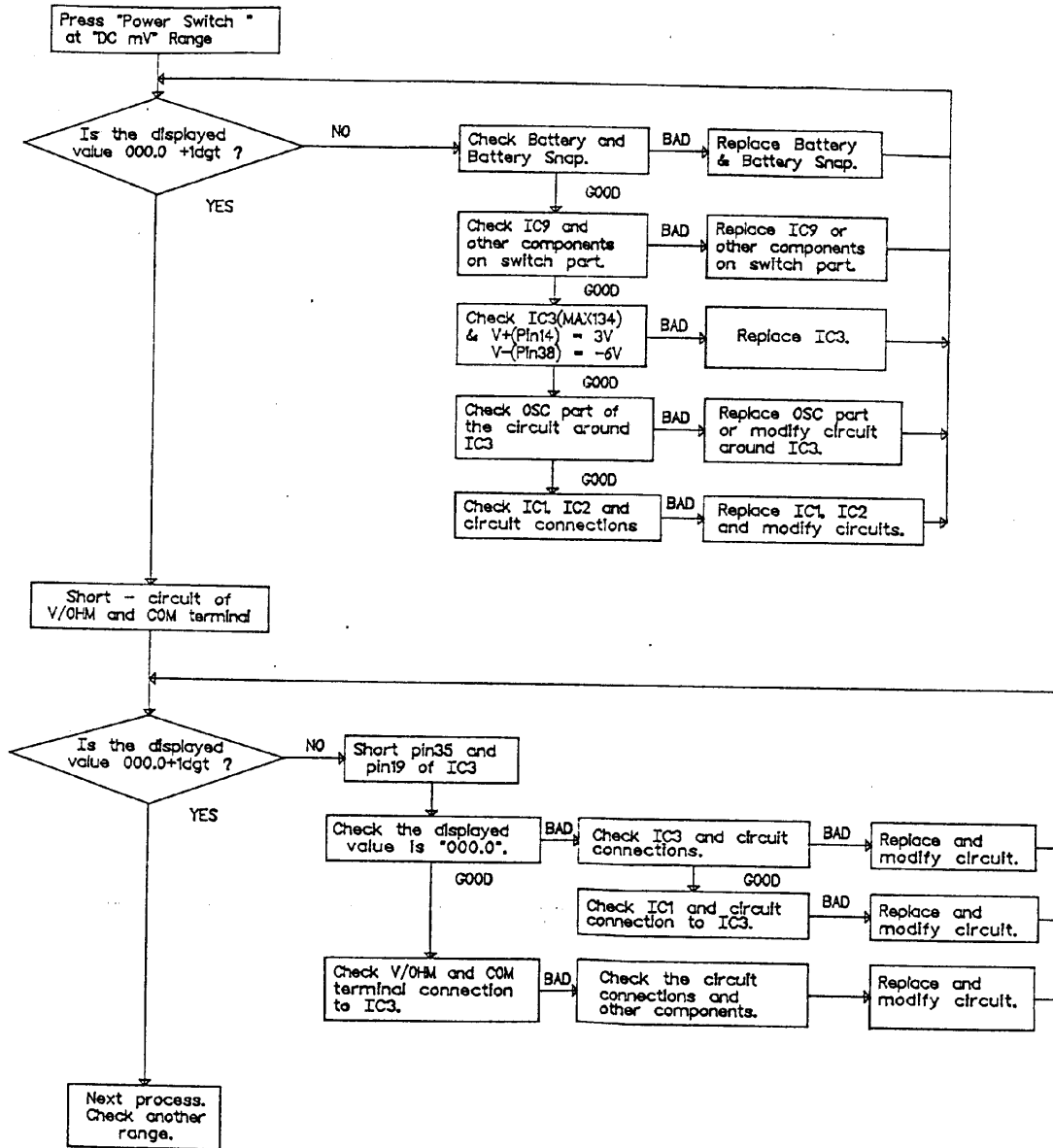

REMARKS :

TITLE					
POWER TROUBLE SHOOTING					
DRAWN	DESIGNED	CHECKED	APPROVED	DATE	1993.5.
				DRAWING	1
METEX INSTRUMENTS				MODEL	M-3850 & M-3830

DC V RANGE

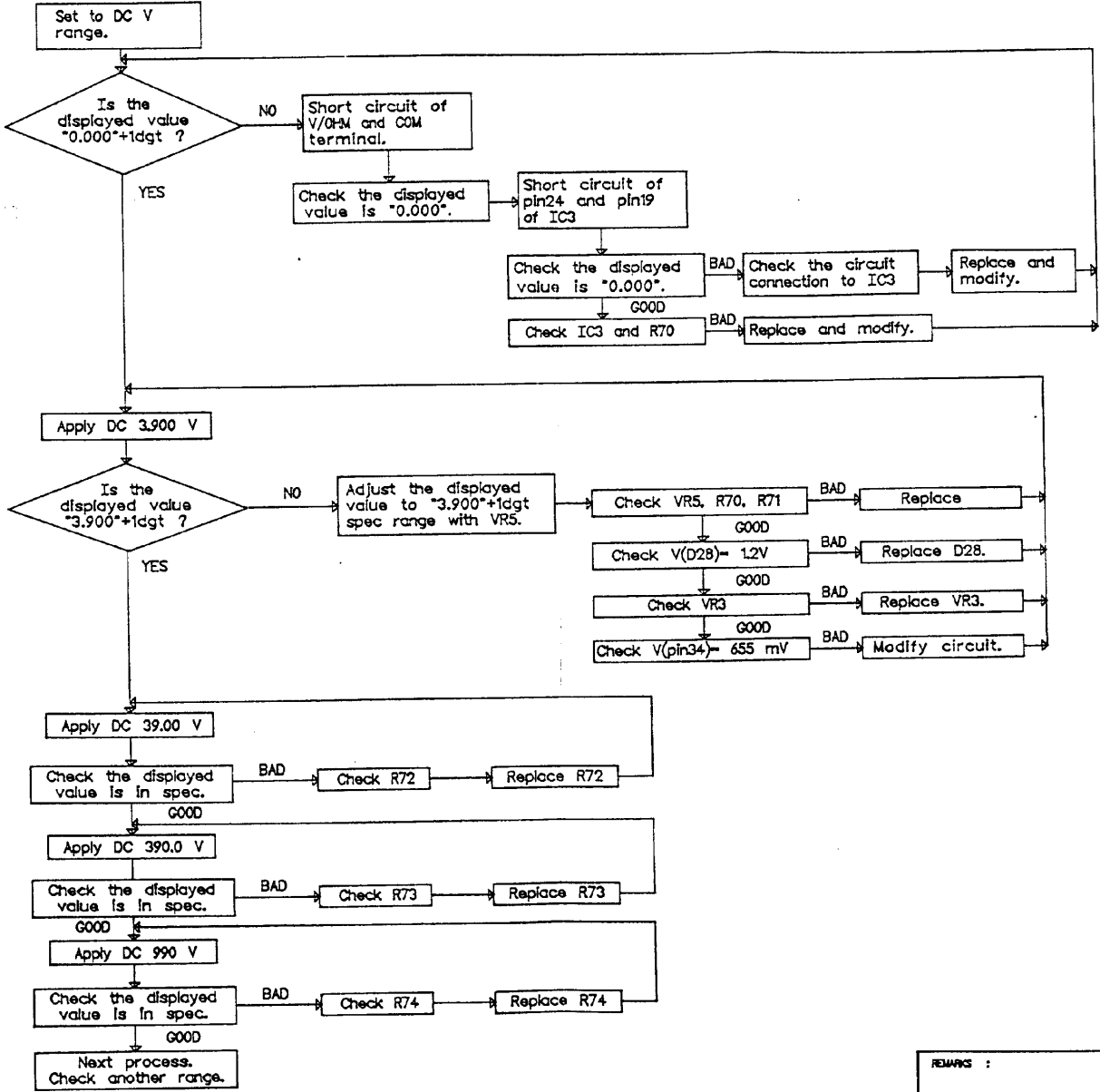

REMARKS :

DC V RANGE TROUBLE SHOOTING				
TITLE	DESIGNED	CHECKED	APPROVED	DATE
				1993.5.6
				DRAWN 4
METEX INSTRUMENTS			MODEL	M-3850 &

AC 400 mV RANGE

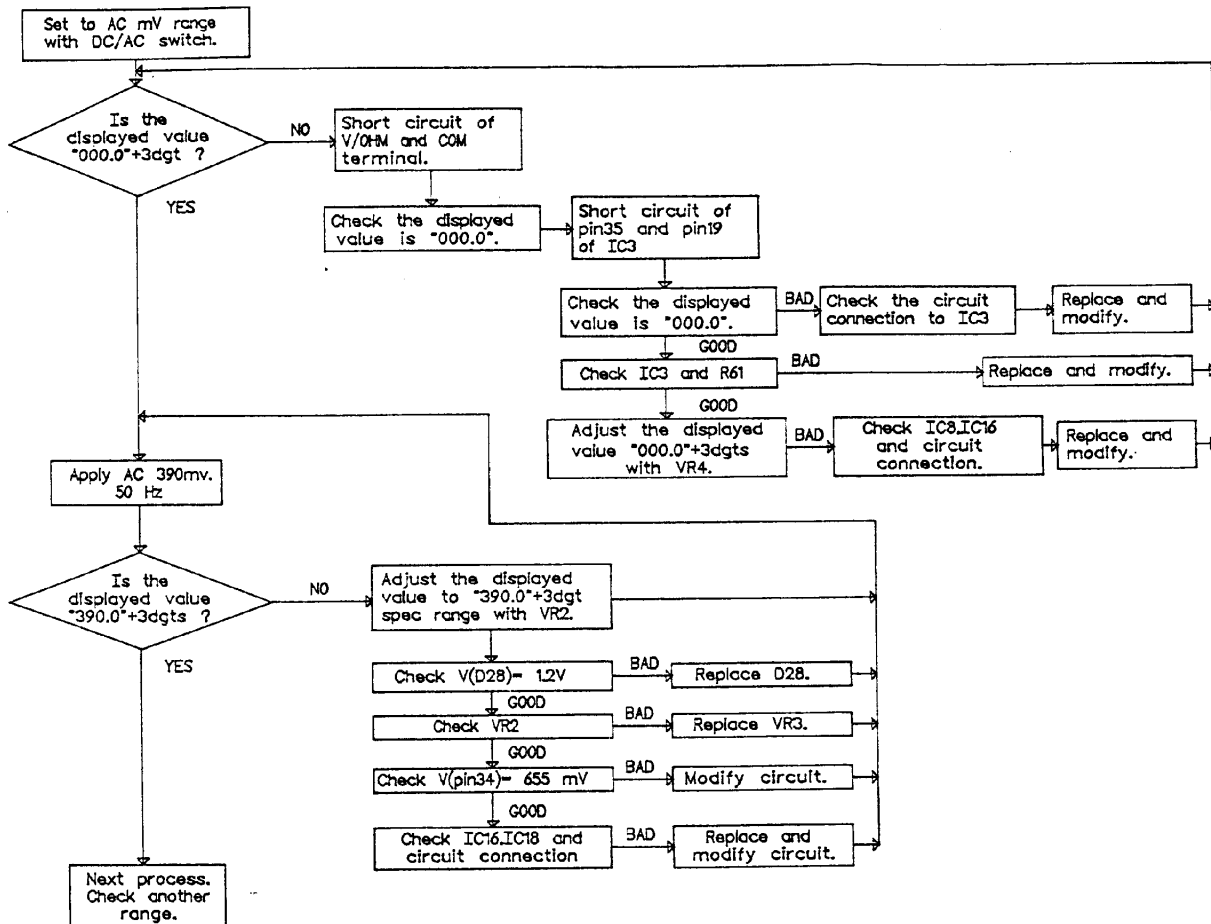

REMARKS :

TITLE		AC mV RANGE TROUBLE SHOOTING			
DRAWN	DESIGNED	CHECKED	APPROVED	DATE	1993.5.
				DWG NO	3
METEX INSTRUMENTS			MODEL	M-3850 & M-3830	

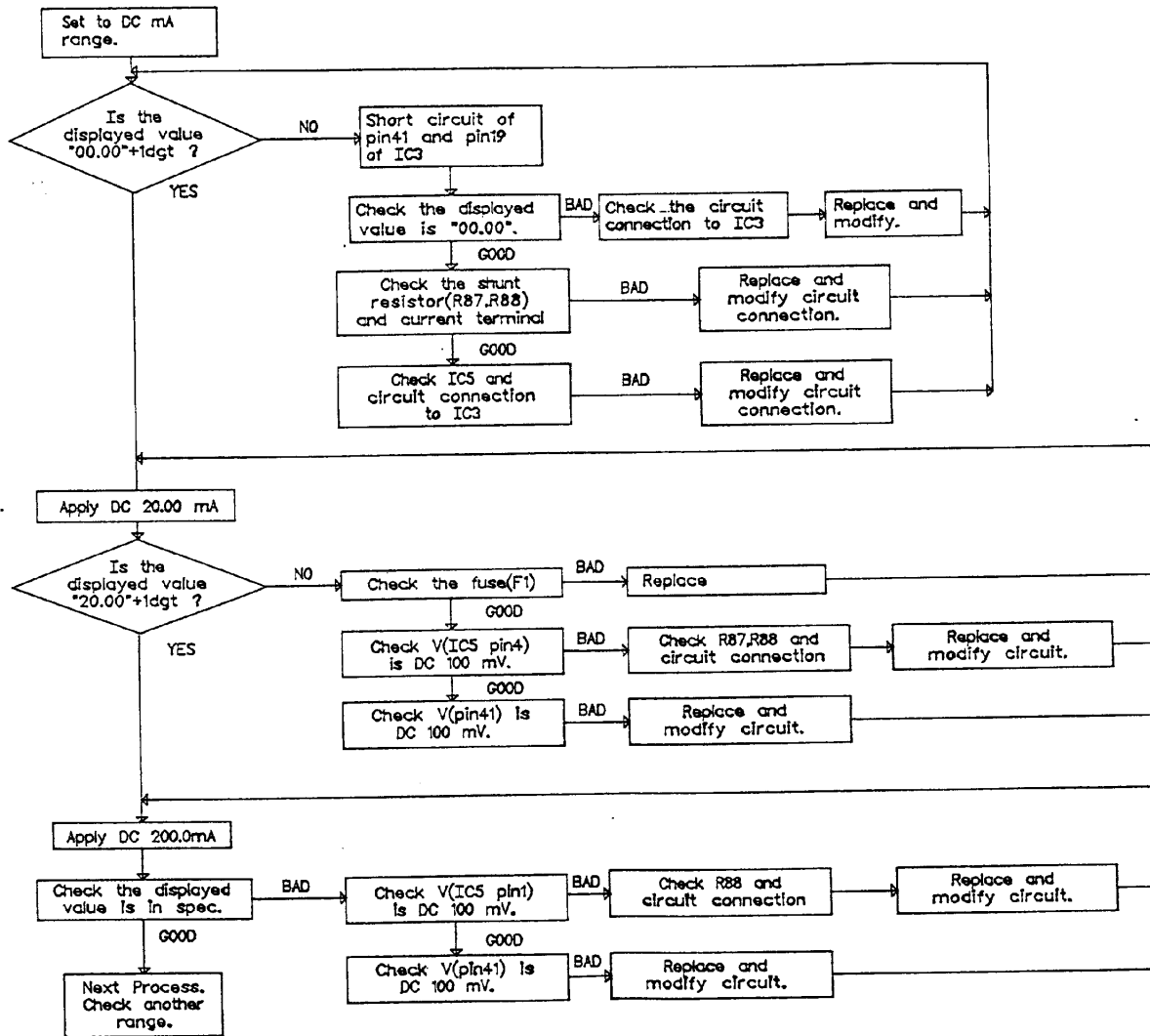

REVISION :	TITLE DC mA RANGE TROUBLE SHOOTING				
	DRAWN	DESIGNED	CHECKED	APPROVED	DATE 1993.5.
					DRAWN 6
	METEX INSTRUMENTS			MODEL	M-3850 & M-3830



AC V RANGE

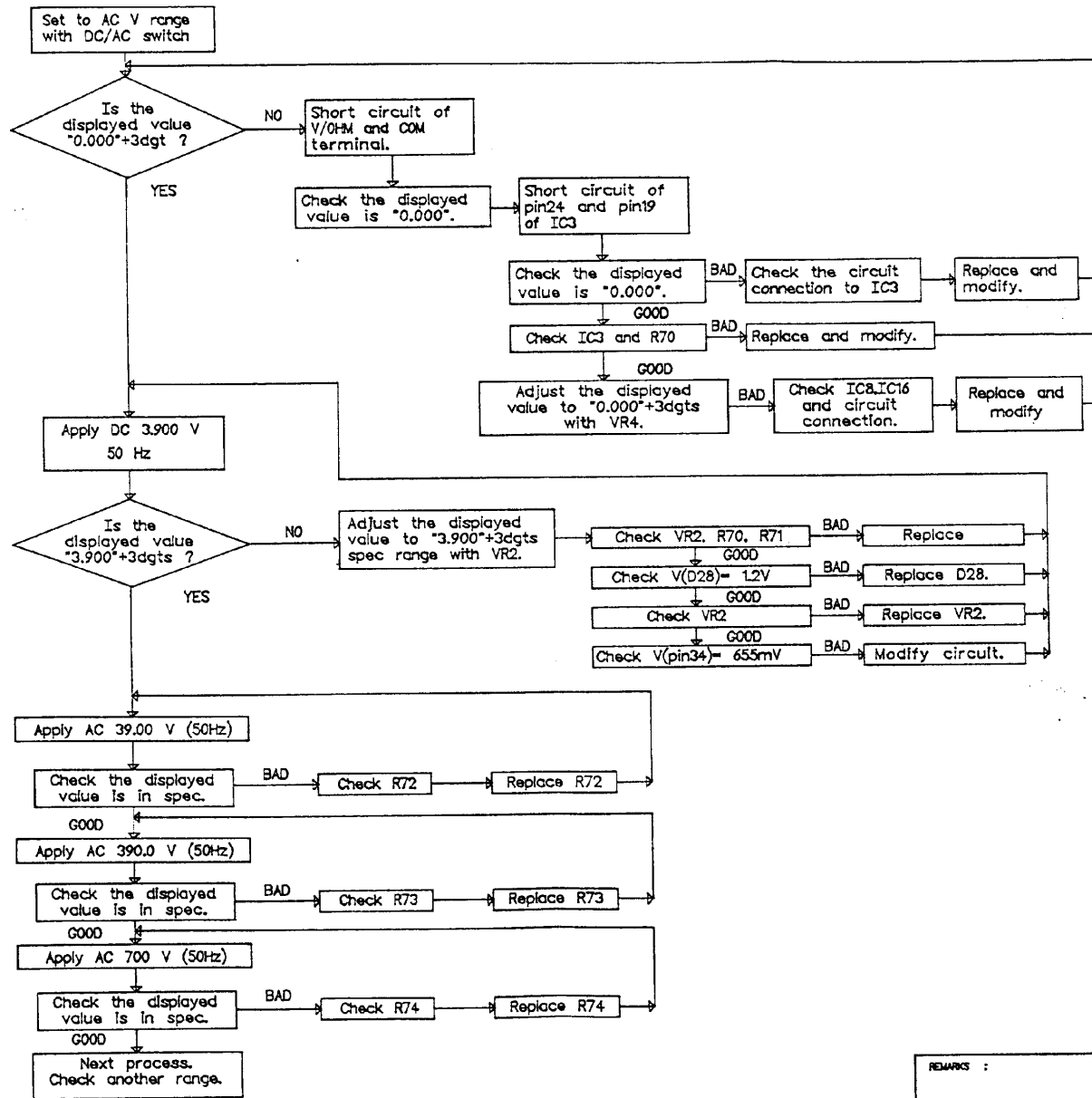

REMARKS :

AC V RANGE TROUBLE SHOOTING					
TITLE	DATE	DATE	DATE	DATE	DATE
DRAWN	DESTINED	CHECKED	APPROVED	DATE	1993.5.6
				DWL NO	5
METEX INSTRUMENTS			MODEL	M-3850 &	

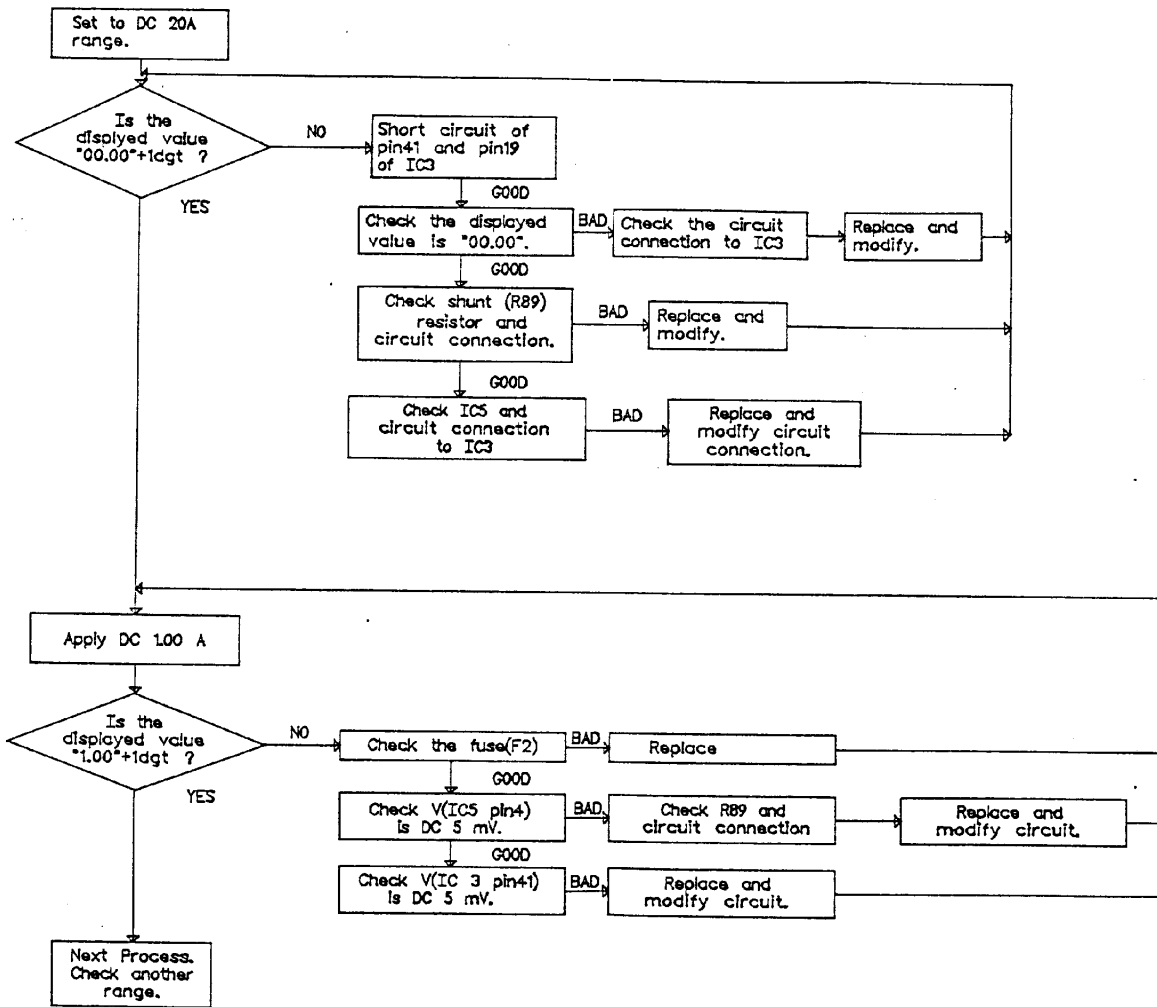

REMARKS :	TITLE DC A RANGE TROUBLE SHOOTING					
	DRAWN	DESIGNED	CHECKED	APPROVED	DATE	1993.5.6
					DRAWN	8
	METEX INSTRUMENTS			MODEL	M-3850 &	

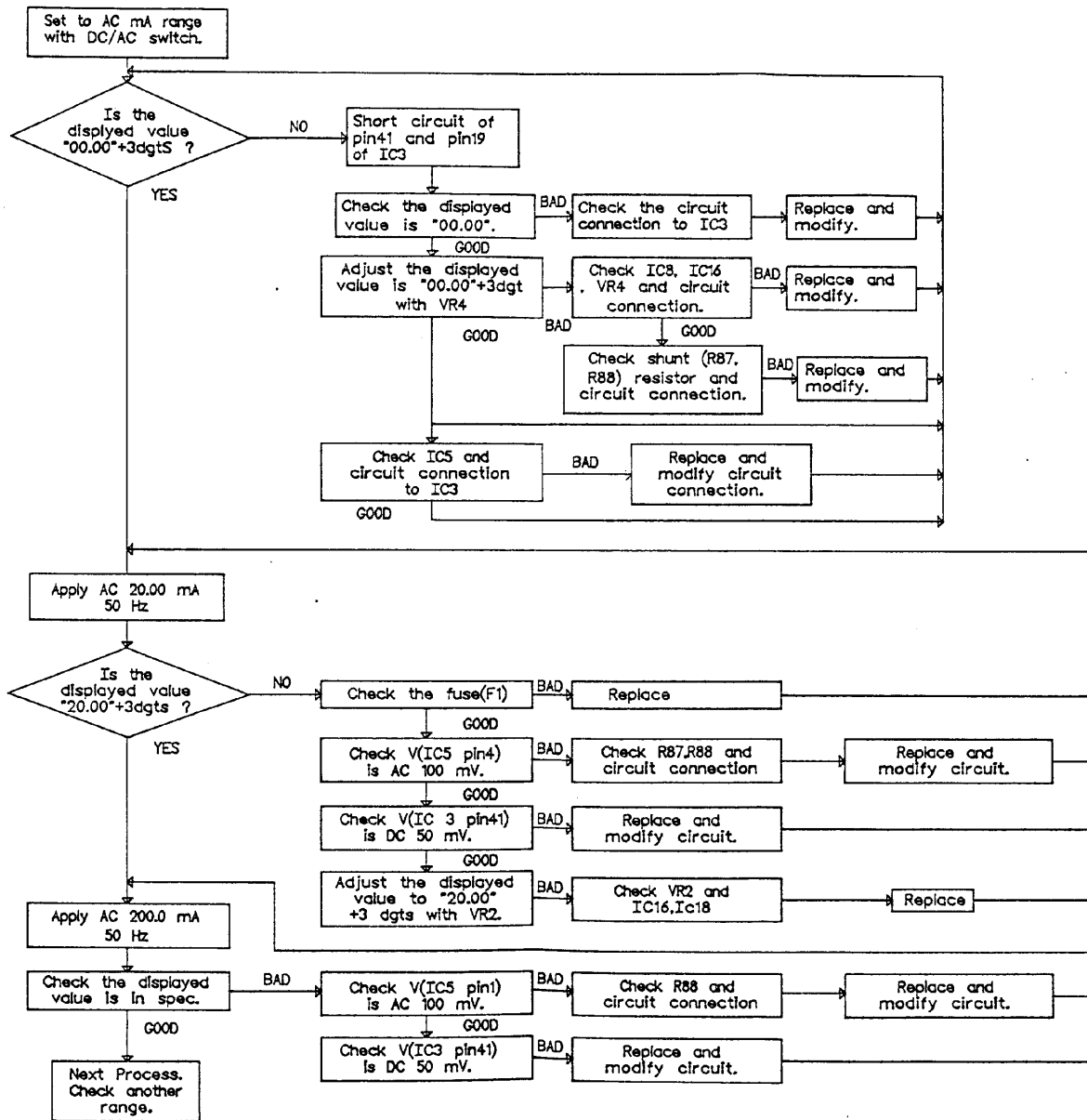

REMARKS :	TITLE AC mA RANGE TROUBLE SHOOTING					
	DRAWN	DESIGNED	CHECKED	APPROVED	DATE	1993.5.6
					DWL NO	7
	METEX INSTRUMENTS			MODEL	M-3850 &	

RESISTANCE RANGE

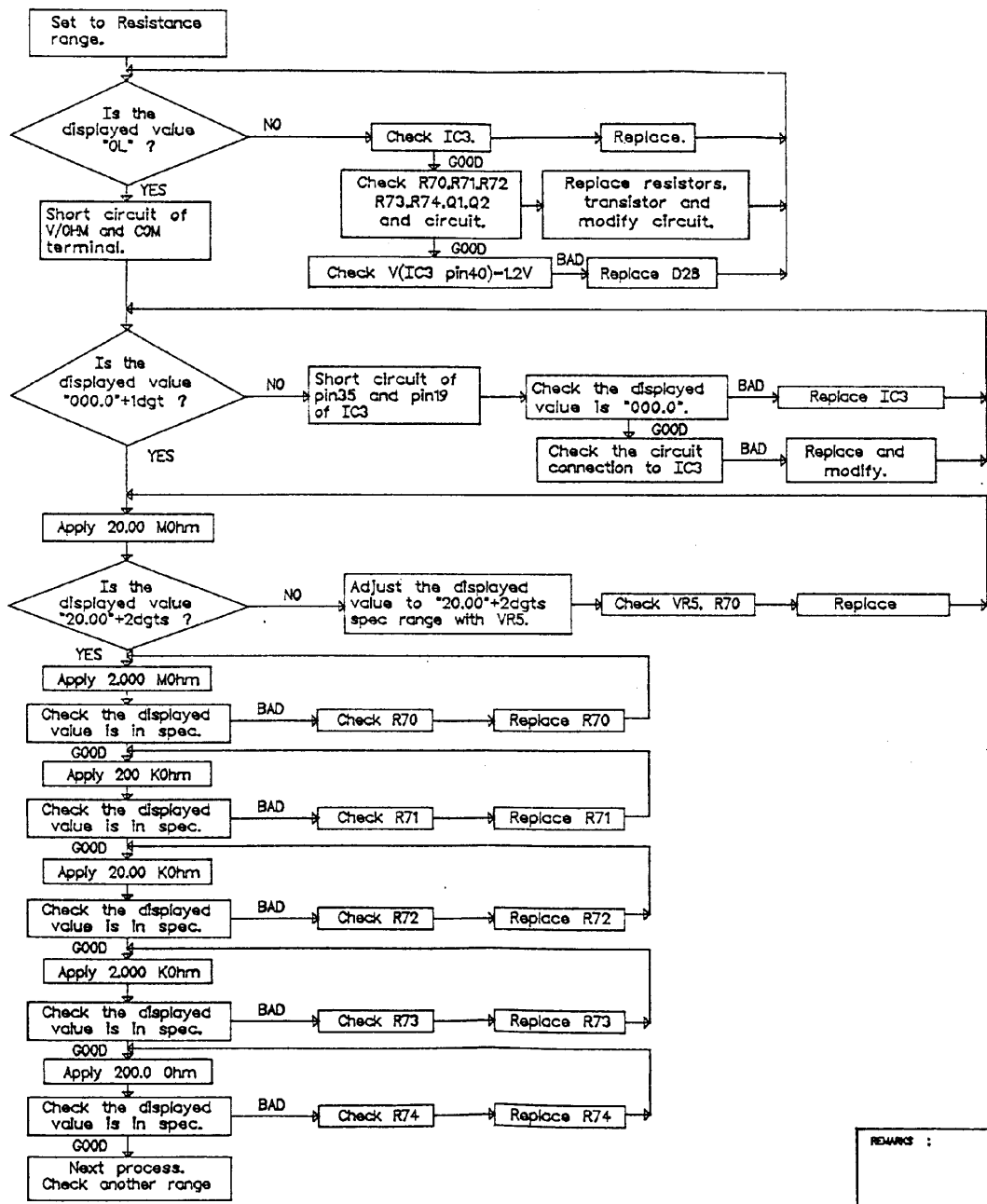

REMARKS :	TITLE RESISTANCE RANGE TROUBLE SHOOTING					
	DRAWN	DESIGNED	CHECKED	APPROVED	DATE	1993.5.6
					DWG. NO	10
	METEX INSTRUMENTS			MODEL	M-3850 &	

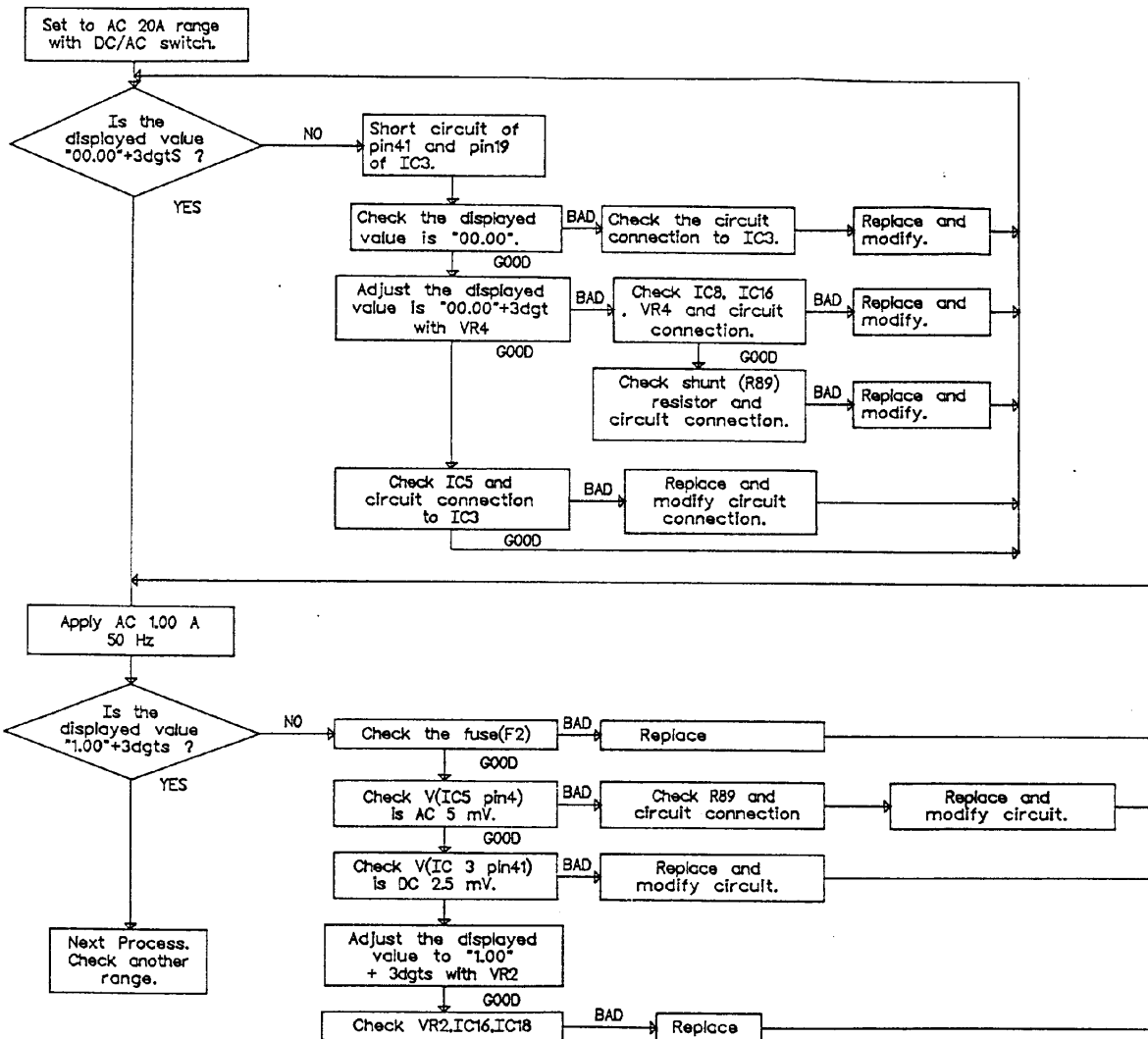

REMARKS :	TITLE AC A RANGE TROUBLE SHOOTING					
	DRAWN	DESIGNED	CHECKED	APPROVED	DATE	1993.5.6
					DWL NO	9
	METEX INSTRUMENTS			MODEL	M-3850 & M-3830	

CAPACITANCE RANGE

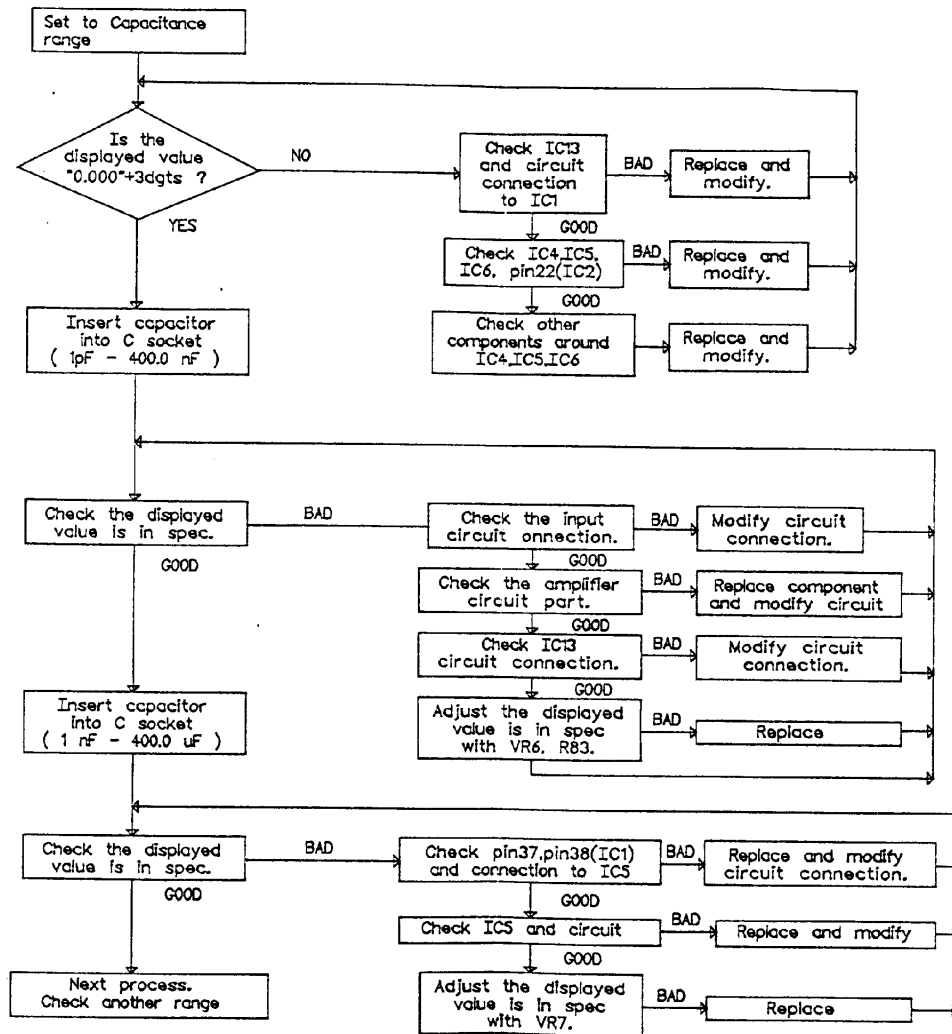

REMARKS :	TITLE CAPACITANCE RANGE TROUBLE SHOOTING					
	DRAWN	DESIGNED	CHECKED	APPROVED	DATE	1993.5.6
					DWG. NO	13
	METEX INSTRUMENTS			MODEL	M-3850 & M-3830	

FREQUENCY RANGE

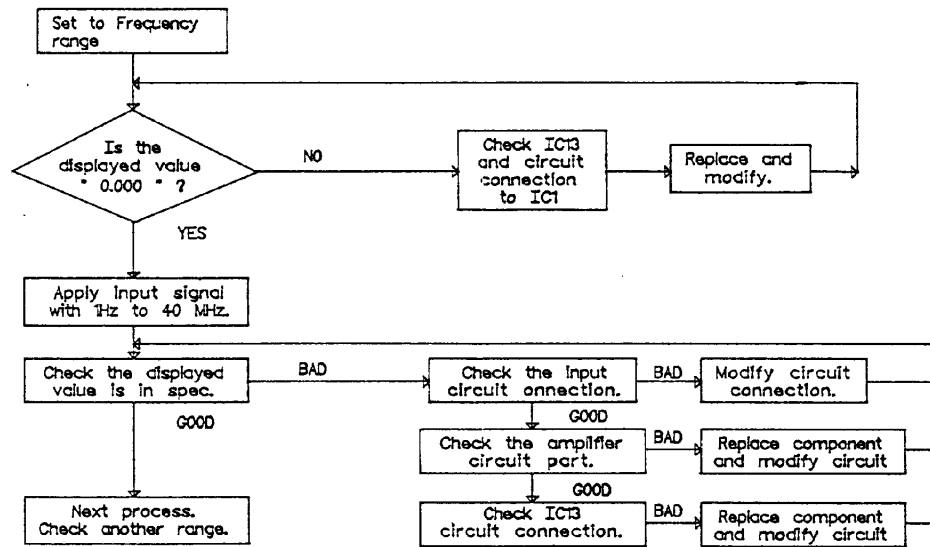

REMARKS :	TITLE FREQUENCY RANGE TROUBLE SHOOTING					
	DRAWN	DESIGNED	CHECKED	APPROVED	DATE	1993.5.
					DRAWING NO	12
	METEX INSTRUMENTS			MODEL	M-3850 &	

DIODE RANGE

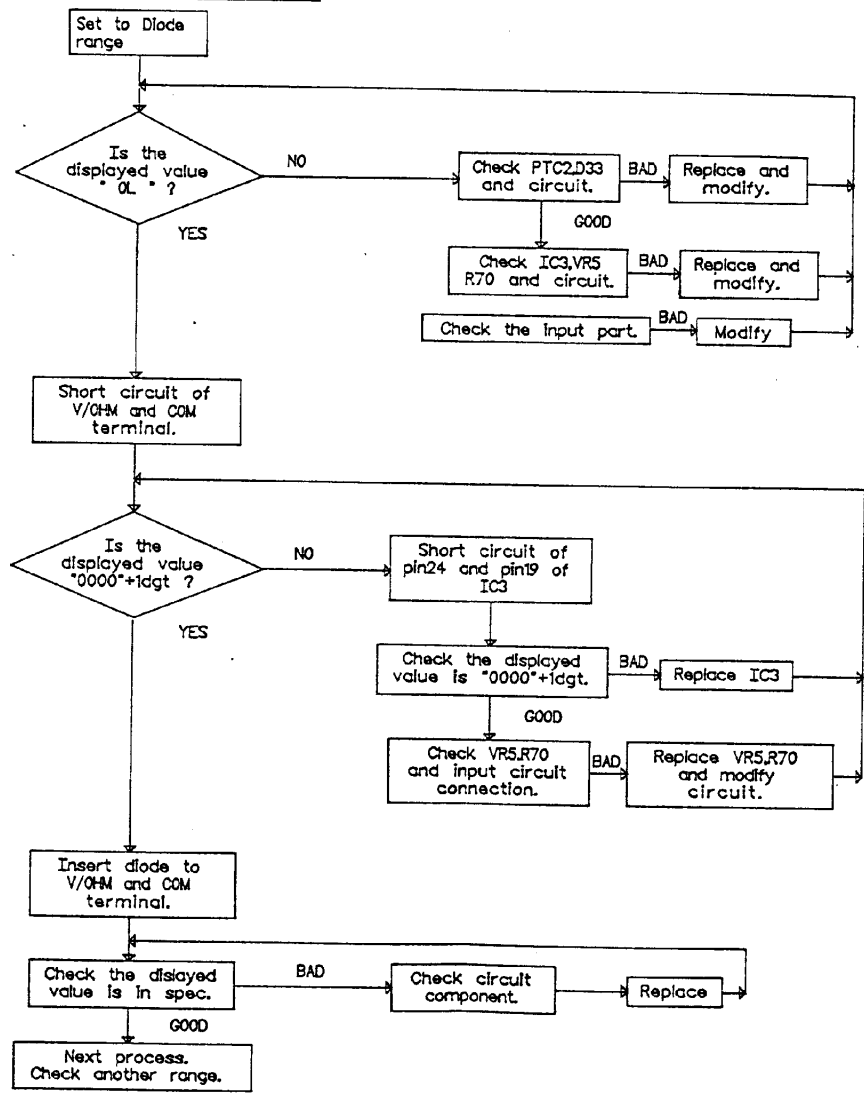

REMARKS :

TITLE					DIODE RANGE TROUBLE SHOOTING				
DRAWN	DESIGNED	CHECKED	APPROVED	DATE	1993.5.6				
				DRAW NO	11				
METEX INSTRUMENTS				MODEL	M-3850 & M-3830				



ROOM TEMPERATURE RANGE

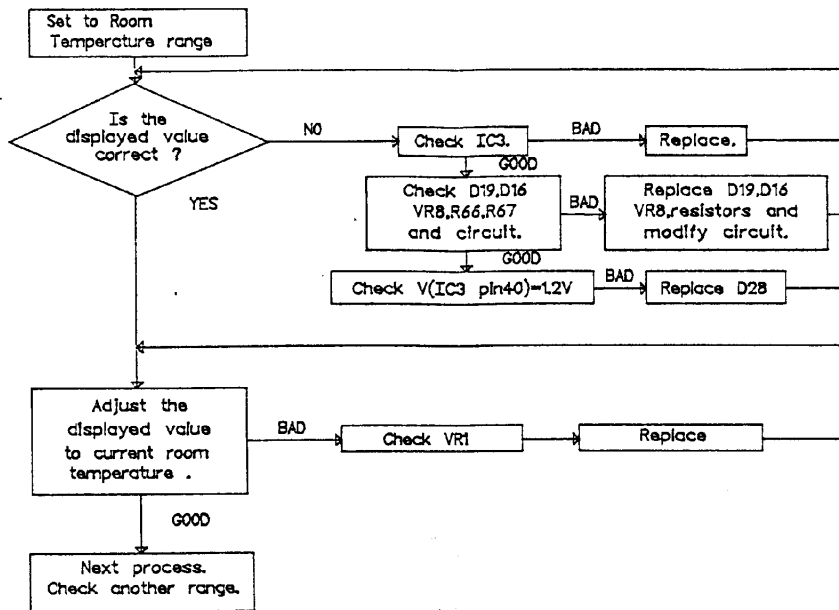

REMARKS :	TITLE TEMPERATURE RANGE TROUBLE SHOOTING					
	DRAWN	DESIGNED	CHECKED	APPROVED	DATE	1993.5.4
					DRAWING	16
	METEX INSTRUMENTS			MODEL	M-3850 & M-3830	

TEMPERATURE RANGE

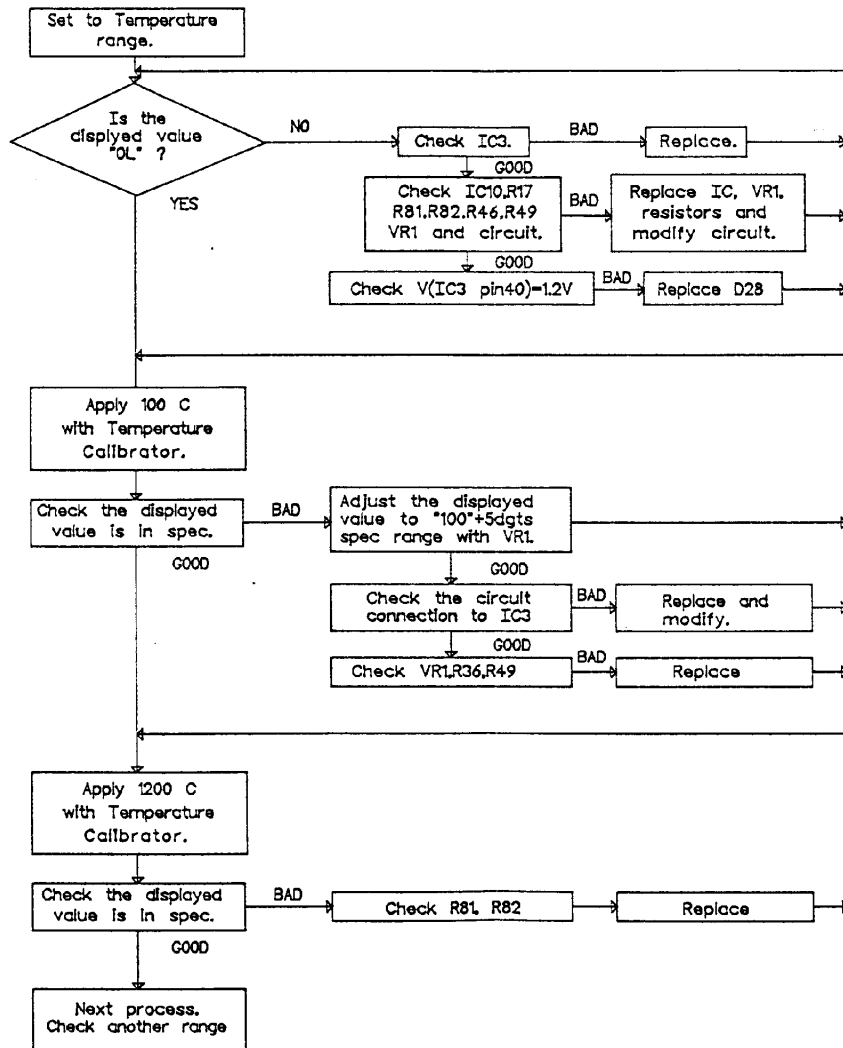

REMARKS :	TITLE TEMPERATURE RANGE TROUBLE SHOOTING					
	DRAWN	DESIGNED	CHECKED	APPROVED	DATE	1993.5.6
					DWG. NO	15
	METEX INSTRUMENTS			MODEL	M-3850 & M-3830	

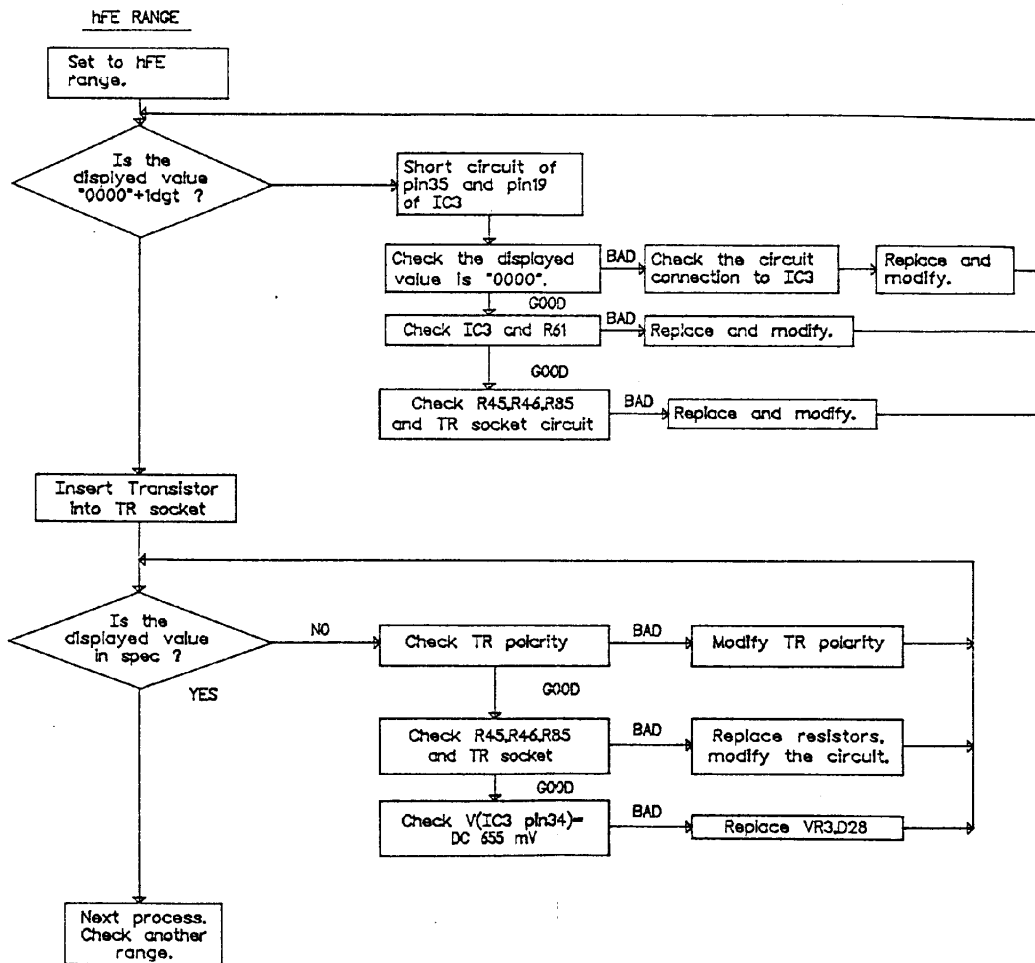

REMARKS :		TITLE hFE RANGE TROUBLE SHOOTING				
		DRAWN	DESIGNED	CHECKED	APPROVED	DATE 1993.5.6
						DWG. NO 14
		METEX INSTRUMENTS		MODEL	M-3850 & M-3830	

COMMUNICATION FUNCTION

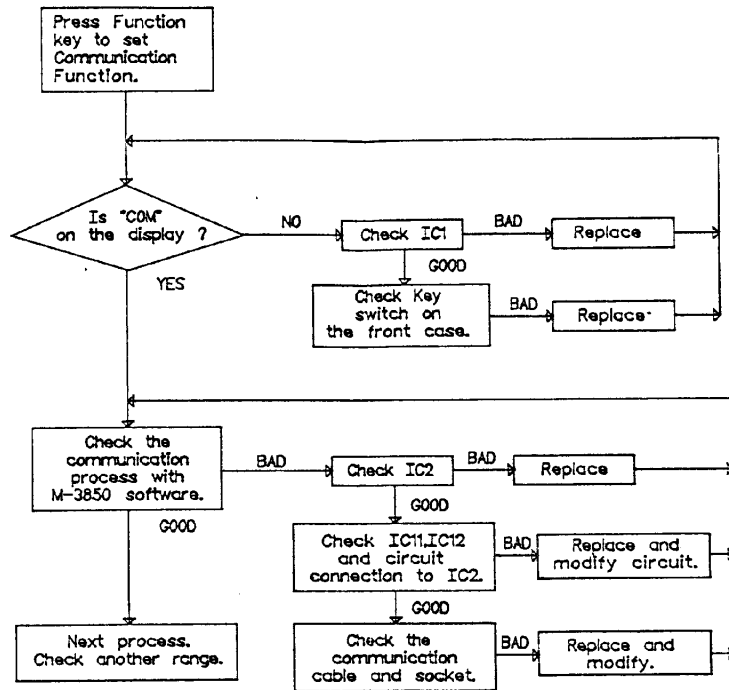

REMARKS :	TITLE COMMUNICATION TROUBLE SHOOTING					
	DRAWN	DESIGNED	CHECKED	APPROVED	DATE	1993.5.6
					DRAWING	18
	METEX INSTRUMENTS			MODEL	M-3850 &	

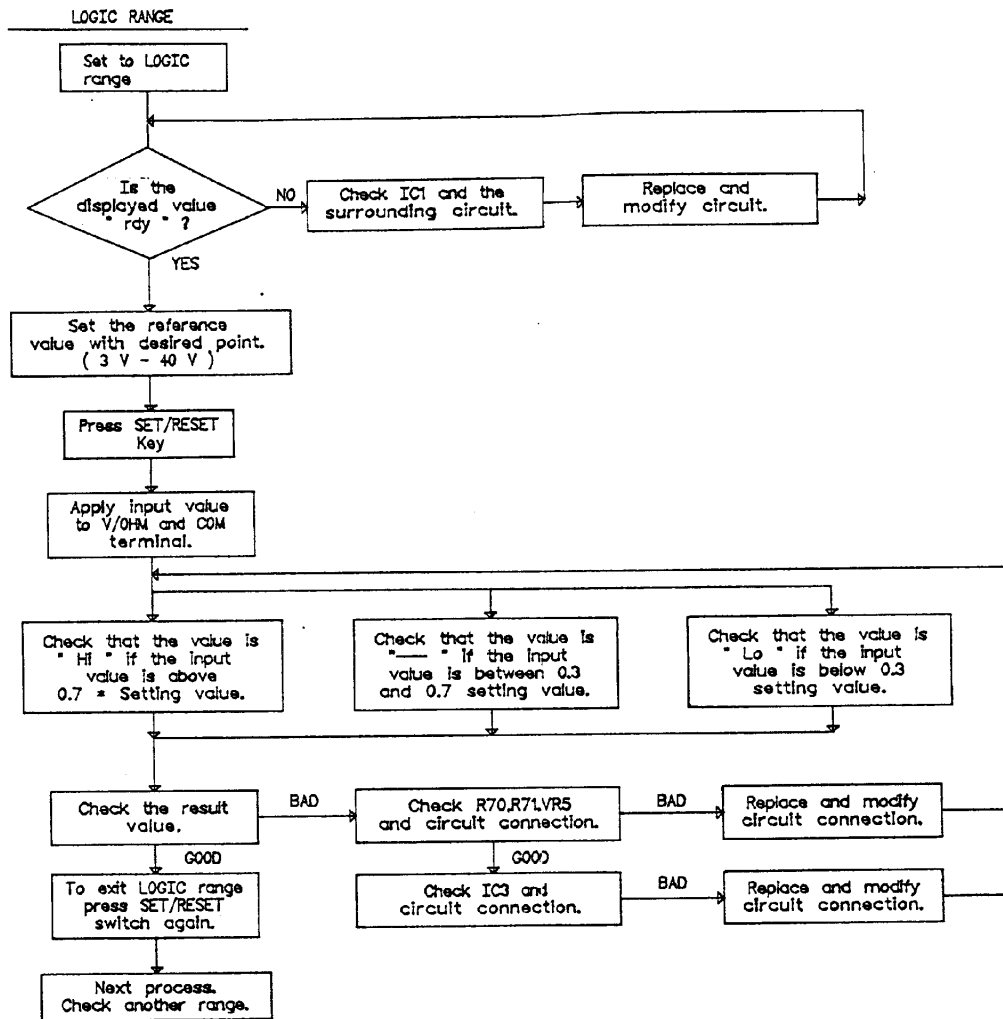

REMARKS :	TITLE LOGIC RANGE TROUBLE SHOOTING					
	DRAWN	DESIGNED	CHECKED	APPROVED	DATE	1993.5.4
					DWG. NO	17
	METEX INSTRUMENTS			MODEL	M-3850 & M-3830	